

The Ultra Quiet High Pressure Fan Coil

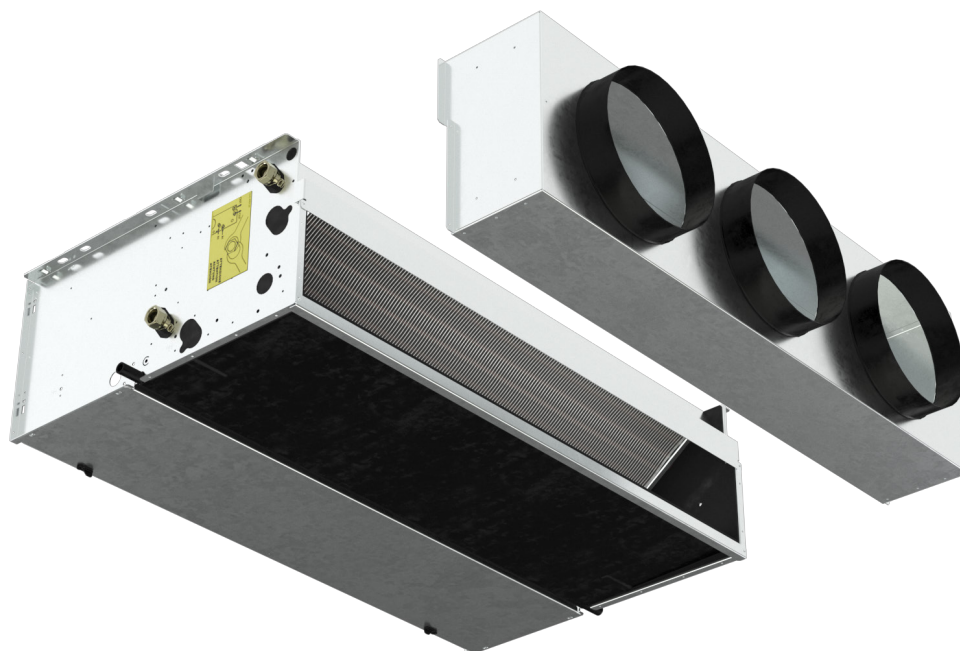

Product is subject to and complies
with Regulation (UE) N.327/2011

Fan Coil Units
Carisma
CRSL
CRSL-ECM

TECHNICAL MANUAL

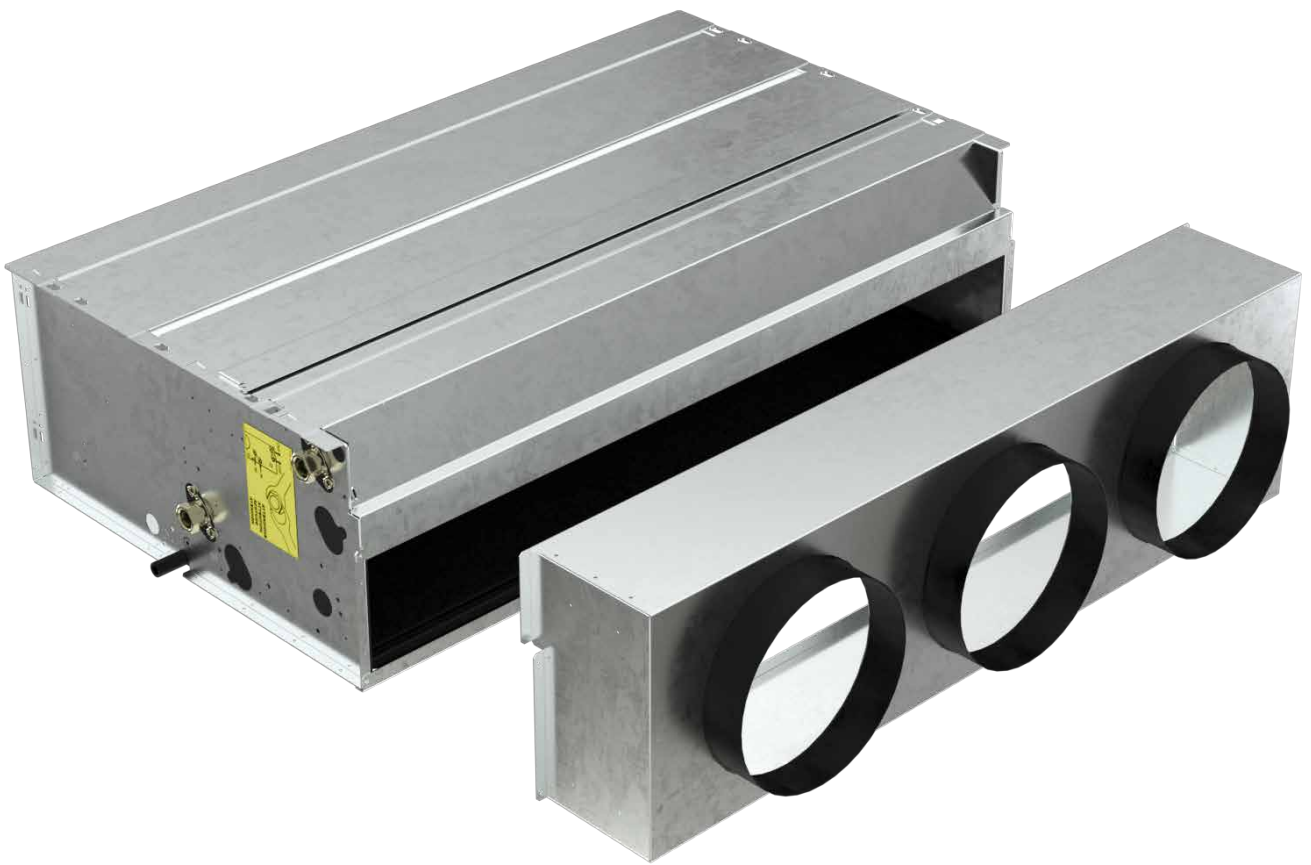

TABLE OF CONTENTS

Introduction

Introduction	p. 4
--------------	------

CRSL

Main components	p. 5
EUROVENT Certifications	p. 6
Main performance and technical characteristics	p. 9
Cooling emission	p. 12
Heating emission	p. 18
Correction factor tables	p. 22
Water side pressure drops	p. 26
Operating limits	p. 27
Dimension, weight and water content	p. 28
Wall electronic controls	p. 30

CRSL-ECM

Main components	p. 31
EUROVENT Certifications	p. 32
Main performance and technical characteristics	p. 34
Cooling emission	p. 36
Heating emission	p. 42
Correction factor tables	p. 46
Water side pressure drops	p. 50
Operating limits	p. 51
Dimension, weight and water content	p. 52

Wall electronic controls	p. 54
--------------------------	-------

CRSL / CRSL-ECM controls

Controls for MB version	p. 55
KNX bus system	p. 57

CRSL / CRSL-ECM accessories

Accessories	p. 58
-------------	-------



Sabiana take part to the Eurovent program of fan coil performance certification. The official figures are published in the web site www.eurovent-certification.com. The tested performances are:

Total cooling emission at the following conditions:

• water temperature	+7 °C E.W.T.	+12 °C L.W.T.
• air temperature	+27 °C d.b.	+19 °C w.b.

Heating emission (2 pipe units) at the following conditions:

• water temperature	+45 °C E.W.T.	+40 °C L.W.T.
• air temperature	+20 °C	

Static pressure	Fan absorption
-----------------	----------------

Sensible cooling emission at the following conditions:

• water temperature	+7 °C E.W.T.	+12 °C L.W.T.
• air temperature	+27 °C d.b.	+19 °C w.b.

Heating emission (4 pipe units) at the following conditions:

• water temperature	+65 °C E.W.T.	+55 °C L.W.T.
• air temperature	+20 °C	

Water side pressure drop	Sound power
--------------------------	-------------

INTRODUCTION

In line with innovative trends and modern industrial design, the Carisma CRSL / CRSL-ECM fan coil range meets today's demanding requirements of performance, size, acoustics, low energy, ease of installation and maintenance.

The fan coil unit has been designed around a platform of models, versions and accessories, all of which have been independently tested and certified by Eurovent.

All fan coils with centrifugal fans are equipped with electric motors which reduce electrical consumption comparative to previous models and are available with both the asynchronous motor and the electronic one with inverter board.

New market trends have also led to an extension of the four pipe model which now has a two row LTHW battery giving improved outputs at lower flow and return temperatures.

A full range of control options is available offering greater flexibility in the installation of units, with the highest precision in monitoring and maintaining the desired comfort conditions.

The model is complemented with a full range of accessories: various types of adjustment valves, additional electric heater, auxiliary condensate pump, air inlet/outlet diffusers for fitted installations.

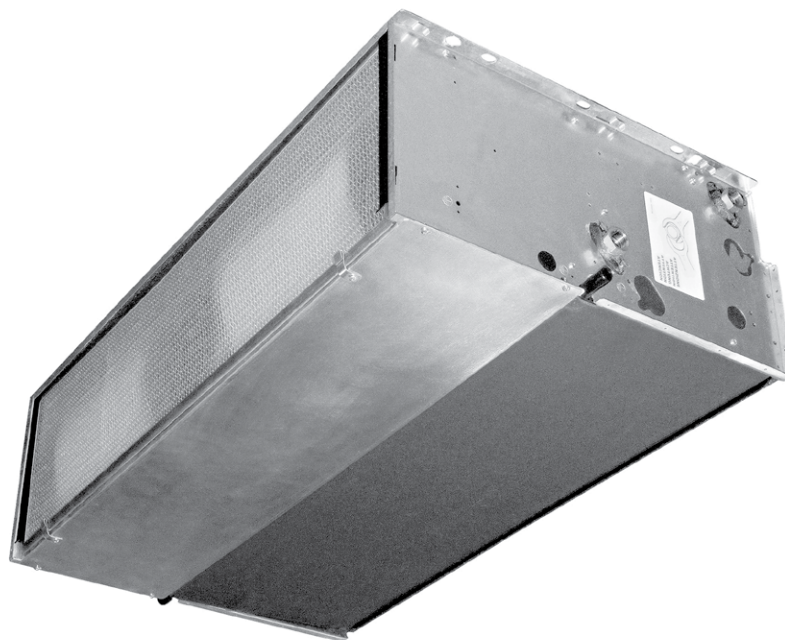
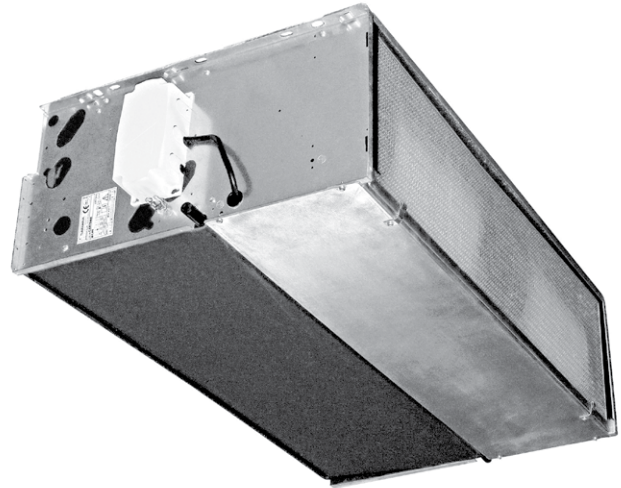

MAIN COMPONENTS

Range includes 7 air flow rates (from 340 to 2100 m³/h), each equipped with 3 or 4 row coil and with the possibility to add a 1 or 2 row coil for 4 pipe systems.

It is the most comprehensive range, perfect to meet all air-conditioning requirements of work environments like offices, shops, restaurants and hotel rooms featuring ducted installations with available pressure up to 80 Pa.

Compliant with Regulation (EU) No. 327/2011.

Casing

Made from 1 mm galvanized steel insulated with 3 mm polyolefin (PO) foam (class M1).

Fan assembly

The fans have aluminium or plastic blades directly keyed on the motor with double aspiration and they are dynamically and statically balanced during manufacture in order to have an extremely quiet operation.

Electric motor

The motor is wired for single phase and has five speeds with capacitor. The motor is fitted on sealed for life bearings and is secured on anti-vibration and self-lubricating mountings. Internal thermal protection with automatic reset, protection IP 20, class B.

Coil

It is manufactured from drawn copper tube and the aluminium fins are mechanically bonded onto the tube by an expansion process. The main coil and additional coil are equipped with two Ø 1/2" BSP female gas connections.

The connections are equipped with Ø 1/8" BSP air vent and drain.

The heat exchanger is not suitable for use in corrosive atmosphere or in environments where aluminium may be subject to corrosion.

The connections are on the left hand side looking from the air outlet of the unit (see picture).

On request or on site the connections can be moved to the other side.

Condensate collection tray

Made of plastic (ABS UL94 HB) for sizes 1÷4 and painted steel for sizes 5÷7 with a L-shaped fitted on the inner casing; the tray is insulated with 3 mm polyolefin (PO) foam (class M1). The outside diameter of the condensate discharge pipe is 15 mm.

Filter

Polypropylene cellular fabric regenerating filter.

The filter frame of galvanized steel is inserted into special plastic sliding guides fastened to the internal structure for easy insertion and removal of the filter.

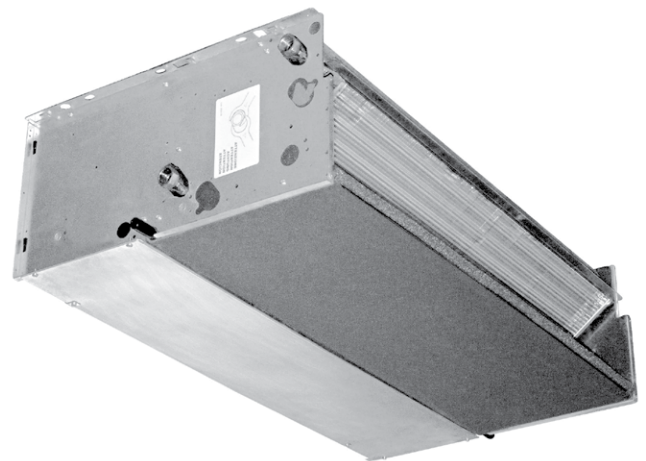

EUROVENT CERTIFICATIONS

3 row coil unit - 2 pipe models

The following standard rating conditions are used:

COOLING

Entering air temperature: + 27 °C d.b. + 19 °C w.b.
Water temperature: +7 °C E.W.T. +12 °C L.W.T.

HEATING

Entering air temperature: + 20 °C
Water temperature: +45 °C E.W.T. +40 °C L.W.T.

MODEL	Speed	CRSL 13			CRSL 23			CRSL 33			CRSL 43		
		1 MIN	4 MED	5 MAX	1 MIN	4 MED	5 MAX	1 MIN	4 MED	5 MAX	1 MIN	4 MED	5 MAX
Air flow (E)	m ³ /h	205	290	315	395	575	625	380	720	790	600	850	980
Available pressure (E)	Pa	25	50	58	26	50	58	14	50	60	23	50	65
Cooling total emission (E)	kW	1,43	1,88	2,00	2,57	3,40	3,60	2,68	4,42	4,72	3,85	4,97	5,47
Cooling sensible emission (E)	kW	1,01	1,35	1,44	1,85	2,53	2,70	1,90	3,30	3,55	2,82	3,77	4,22
Heating emission (E)	kW	1,43	1,96	2,11	2,67	3,70	3,98	2,71	4,82	5,22	4,10	5,56	6,27
Dp Cooling (E)	kPa	11,0	17,0	20,0	10,6	17,7	19,6	6,3	15,7	17,7	12,2	19,4	23,2
Dp Heating (E)	kPa	9,0	16,0	18,0	8,9	16,1	18,3	5,1	14,3	16,6	10,7	18,6	23,0
Motor power input (E)	W	27	45	51	59	87	94	50	96	110	89	120	146
Sound power outlet (Lw) (E)	dB(A)	34	42	43	38	47	49	36	48	51	44	52	55
Sound power inlet + radiated (Lw) (E)	dB(A)	42	50	52	45	55	56	43	56	58	51	59	62
Sound pressure level outlet (Lp) ⁽¹⁾	dB(A)	25	33	34	29	38	40	27	39	42	35	43	46
Sound pressure level inlet + radiated (Lp) ⁽¹⁾	dB(A)	33	41	43	36	46	47	34	47	49	42	50	53
Plenum code (E)		9069191	9069191	9069191	9069222	9069222	9069222	9066368	9066368	9066368	9066368	9066368	9066368

MODEL	Speed	CRSL 53			CRSL 63			CRSL 73		
		1 MIN	4 MED	5 MAX	1 MIN	4 MED	5 MAX	1 MIN	3 MED	4 MAX
Air flow (E)	m ³ /h	475	810	970	580	1120	1240	905	1270	1425
Available pressure (E)	Pa	18	50	70	15	50	60	26	50	63
Cooling total emission (E)	kW	3,30	5,04	5,72	3,99	6,62	7,11	5,58	7,11	7,70
Cooling sensible emission (E)	kW	2,31	3,64	4,19	2,83	4,94	5,36	4,06	5,37	5,89
Heating emission (E)	kW	3,33	5,36	6,25	3,94	6,96	7,58	5,82	7,73	8,49
Dp Cooling (E)	kPa	12,2	26,3	33,1	6,6	16,4	18,7	12,2	18,8	21,7
Dp Heating (E)	kPa	9,7	23,0	30,4	5,1	14,2	16,5	10,3	17,1	20,2
Motor power input (E)	W	65	110	140	66	125	145	155	177	186
Sound power outlet (Lw) (E)	dB(A)	37	48	53	38	50	52	46	53	56
Sound power inlet + radiated (Lw) (E)	dB(A)	43	56	60	46	58	60	53	60	63
Sound pressure level outlet (Lp) ⁽¹⁾	dB(A)	28	39	44	29	41	43	37	44	47
Sound pressure level inlet + radiated (Lp) ⁽¹⁾	dB(A)	34	47	51	37	49	51	44	51	54
Plenum code (E)		9069195	9069195	9069195	9069196	9069196	9069196	9069196	9069196	9069196

(E) Eurovent certified performance.

(1) The sound pressure levels are 9 dB (A) lower than the sound power levels, apply to the reverberant field of a 100 m³ room and a reverberation time of 0.5 sec.

4 row coil unit - 2 pipe models

The following standard rating conditions are used:

COOLING

Entering air temperature: + 27 °C d.b. + 19 °C w.b.
 Water temperature: +7 °C E.W.T. +12 °C L.W.T.

HEATING

Entering air temperature: + 20 °C
 Water temperature: +45 °C E.W.T. +40 °C L.W.T.

MODEL	Speed	CRSL 14			CRSL 24			CRSL 34			CRSL 44		
		1 MIN	4 MED	5 MAX	1 MIN	4 MED	5 MAX	1 MIN	4 MED	5 MAX	1 MIN	4 MED	5 MAX
Air flow (E)	m ³ /h	205	290	315	395	575	625	380	720	790	600	850	980
Available pressure (E)	Pa	25	50	58	26	50	58	14	50	60	23	50	65
Cooling total emission (E)	kW	1,54	2,07	2,22	2,93	4,01	4,28	2,89	4,99	5,36	4,10	5,36	5,94
Cooling sensible emission (E)	kW	1,07	1,46	1,57	2,03	2,84	3,04	2,00	3,55	3,84	2,95	3,97	4,46
Heating emission (E)	kW	1,49	2,07	2,23	2,85	4,02	4,34	2,76	4,99	5,42	4,22	5,77	6,55
Dp Cooling (E)	kPa	5,6	9,7	11,0	15,8	27,9	31,3	11,8	31,7	36,1	7,9	12,9	15,6
Dp Heating (E)	kPa	5,1	9,2	10,5	12,3	22,8	26,2	8,6	24,9	28,9	6,6	11,5	14,5
Motor power input (E)	W	27	45	51	59	87	94	50	96	110	89	120	146
Sound power outlet (Lw) (E)	dB(A)	34	42	43	38	47	49	36	48	51	44	52	55
Sound power inlet + radiated (Lw) (E)	dB(A)	42	50	52	45	55	56	43	56	58	51	59	62
Sound pressure level outlet (Lp) ⁽¹⁾	dB(A)	25	33	34	29	38	40	27	39	42	35	43	46
Sound pressure level inlet + radiated (Lp) ⁽¹⁾	dB(A)	33	41	43	36	46	47	34	47	49	42	50	53
Plenum code (E)		9069191	9069191	9069191	9069222	9069222	9069222	9066368	9066368	9066368	9066368	9066368	9066368

MODEL	Speed	CRSL 54			CRSL 64			CRSL 74		
		1 MIN	4 MED	5 MAX	1 MIN	4 MED	5 MAX	1 MIN	3 MED	4 MAX
Air flow (E)	m ³ /h	475	810	970	580	1120	1240	905	1270	1425
Available pressure (E)	Pa	18	50	70	15	50	60	26	50	63
Cooling total emission (E)	kW	3,48	5,44	6,22	4,23	7,25	7,82	6,10	7,92	8,62
Cooling sensible emission (E)	kW	2,43	3,89	4,52	2,96	5,26	5,72	4,34	5,80	6,38
Heating emission (E)	kW	3,41	5,57	6,54	4,17	7,63	8,34	6,30	8,52	9,42
Dp Cooling (E)	kPa	6,3	14,2	18,1	5,1	13,6	15,6	10,1	16,1	18,7
Dp Heating (E)	kPa	5,2	12,5	16,7	4,3	12,7	15,0	9,0	15,6	18,6
Motor power input (E)	W	65	110	140	66	125	145	155	177	186
Sound power outlet (Lw) (E)	dB(A)	37	48	53	38	50	52	46	53	56
Sound power inlet + radiated (Lw) (E)	dB(A)	43	56	60	46	58	60	53	60	63
Sound pressure level outlet (Lp) ⁽¹⁾	dB(A)	28	39	44	29	41	43	37	44	47
Sound pressure level inlet + radiated (Lp) ⁽¹⁾	dB(A)	34	47	51	37	49	51	44	51	54
Plenum code (E)		9069195	9069195	9069195	9069196	9069196	9069196	9069196	9069196	9069196

(E) Eurovent certified performance.

(1) The sound pressure levels are 9 dB (A) lower than the sound power levels, apply to the reverberant field of a 100 m³ room and a reverberation time of 0.5 sec.

3+1 row coil unit - 4 pipe models

The following standard rating conditions are used:

COOLING

Entering air temperature: + 27 °C d.b. + 19 °C w.b.
Water temperature: +7 °C E.W.T. +12 °C L.W.T.

HEATING

Entering air temperature: + 20 °C
Water temperature: +65 °C E.W.T. +55 °C L.W.T.

MODEL	Speed	CRSL 13+1			CRSL 23+1			CRSL 33+1			CRSL 43+1		
		1 MIN	4 MED	5 MAX	1 MIN	4 MED	5 MAX	1 MIN	4 MED	5 MAX	1 MIN	4 MED	5 MAX
Air flow (E)	m ³ /h	205	290	315	395	575	625	380	720	790	600	850	980
Available pressure (E)	Pa	25	50	58	26	50	58	14	50	60	23	50	65
Cooling total emission (E)	kW	1,43	1,88	2,00	2,57	3,40	3,60	2,68	4,42	4,72	3,85	4,97	5,47
Cooling sensible emission (E)	kW	1,01	1,35	1,44	1,85	2,53	2,70	1,90	3,30	3,55	2,82	3,77	4,22
Heating emission (E)	kW	1,30	1,66	1,76	2,22	2,85	3,02	2,38	3,68	3,91	3,26	4,10	4,49
Dp Cooling (E)	kPa	10,5	17,4	19,5	10,6	17,7	19,6	6,3	15,7	17,7	12,2	19,4	23,2
Dp Heating (E)	kPa	4,4	6,8	7,5	2,8	4,3	4,8	3,1	6,7	7,5	5,4	8,2	9,6
Motor power input (E)	W	27	45	51	59	87	94	50	96	110	89	120	146
Sound power outlet (Lw) (E)	dB(A)	34	42	43	38	47	49	36	48	51	44	52	55
Sound power inlet + radiated (Lw) (E)	dB(A)	42	50	52	45	55	56	43	56	58	51	59	62
Sound pressure level outlet (Lp) ⁽¹⁾	dB(A)	25	33	34	29	38	40	27	39	42	35	43	46
Sound pressure level inlet + radiated (Lp) ⁽¹⁾	dB(A)	33	41	43	36	46	47	34	47	49	42	50	53
Plenum code (E)		9069191	9069191	9069191	9069222	9069222	9069222	9066368	9066368	9066368	9066368	9066368	9066368

MODEL	Speed	CRSL 53+1			CRSL 63+1			CRSL 73+1		
		1 MIN	4 MED	5 MAX	1 MIN	4 MED	5 MAX	1 MIN	3 MED	4 MAX
Air flow (E)	m ³ /h	475	810	970	580	1120	1240	905	1270	1425
Available pressure (E)	Pa	18	50	70	15	50	60	26	50	63
Cooling total emission (E)	kW	3,32	5,10	5,78	3,99	6,62	7,11	5,58	7,11	7,70
Cooling sensible emission (E)	kW	2,33	3,67	4,23	2,83	4,94	5,36	4,06	5,37	5,89
Heating emission (E)	kW	2,85	4,11	4,63	3,48	5,44	5,80	4,72	5,90	6,35
Dp Cooling (E)	kPa	12,3	26,7	33,7	6,6	16,4	18,7	12,2	18,8	21,7
Dp Heating (E)	kPa	3,8	7,4	9,1	6,1	13,7	15,3	10,6	15,8	18,1
Motor power input (E)	W	65	110	140	66	125	145	155	177	186
Sound power outlet (Lw) (E)	dB(A)	37	48	53	38	50	52	46	53	56
Sound power inlet + radiated (Lw) (E)	dB(A)	43	56	60	46	58	60	53	60	63
Sound pressure level outlet (Lp) ⁽¹⁾	dB(A)	28	39	44	29	41	43	37	44	47
Sound pressure level inlet + radiated (Lp) ⁽¹⁾	dB(A)	34	47	51	37	49	51	44	51	54
Plenum code (E)		9069195	9069195	9069195	9069196	9069196	9069196	9069196	9069196	9069196

(E) Eurovent certified performance.

(1) The sound pressure levels are 9 dB (A) lower than the sound power levels, apply to the reverberant field of a 100 m³ room and a reverberation time of 0.5 sec.

MAIN PERFORMANCE AND TECHNICAL CHARACTERISTICS

3 row coil unit - 2 pipe models

The following standard rating conditions are used:

COOLING

Entering air temperature: + 27 °C d.b. + 19 °C w.b.
Water temperature: +7 °C E.W.T. +12 °C L.W.T.

HEATING

Entering air temperature: + 20 °C
Water temperature: +45 °C E.W.T. +40 °C L.W.T.

Available pressure: 0 Pa

MODEL	Speed	CRSL 13					CRSL 23					CRSL 33					CRSL 43				
		1	2	3	4	5	1	2	3	4	5	1	2	3	4	5	1	2	3	4	5
		MIN			MED	MAX	MIN			MED	MAX	MIN			MED	MAX	MIN			MED	MAX
Air flow	m ³ /h	340	400	445	490	535	515	600	660	780	860	500	620	750	960	1115	655	815	955	1080	1340
Cooling total emission	kW	2,14	2,41	2,59	2,81	2,93	3,16	3,52	3,75	4,29	4,47	3,36	3,98	4,57	5,54	6,00	4,12	4,83	5,39	6,00	6,74
Cooling sensible emission	kW	1,57	1,78	1,94	2,09	2,24	2,33	2,63	2,84	3,23	3,49	2,44	2,93	3,43	4,19	4,72	3,04	3,65	4,15	4,58	5,43
Heating emission	kW	2,25	2,59	2,84	3,08	3,31	3,37	3,84	4,16	4,78	5,18	3,48	4,22	4,98	6,16	6,99	4,43	5,36	6,14	6,80	8,11
Dp Cooling	kPa	21,7	26,8	30,7	34,6	38,5	15,3	18,6	21,0	25,7	28,8	9,4	12,8	16,5	22,6	27,1	13,8	18,4	22,4	26,1	33,7
Dp Heating	kPa	20,2	26,0	30,6	35,4	40,3	13,6	17,2	19,8	25,4	29,4	8,0	11,3	15,2	22,3	28,0	12,3	17,4	22,2	26,7	36,6
Motor power input	W	28	35	41	47	55	62	74	82	98	110	50	64	80	106	126	93	110	127	142	175
Sound power (Lw)	dB(A)	40	43	46	48	51	42	46	48	52	55	38	43	48	54	57	45	51	55	58	63
Sound pressure (Lp) ⁽¹⁾	dB(A)	31	34	37	39	42	33	37	39	43	46	29	34	39	44	48	36	42	46	49	54

MODEL	Speed	CRSL 53					CRSL 63					CRSL 73				
		1	2	3	4	5	1	2	3	4	5	1	2	3	4	5
		MIN			MED	MAX	MIN			MED	MAX	MIN			MED	MAX
Air flow	m ³ /h	595	760	895	1030	1375	720	1015	1210	1425	1635	970	1190	1490	1810	2100
Cooling total emission	kW	3,98	4,82	5,43	6,11	7,24	4,77	6,19	7,01	7,97	8,56	5,87	6,78	7,90	9,22	9,89
Cooling sensible emission	kW	2,82	3,46	3,95	4,42	5,53	3,44	4,58	5,27	5,99	6,67	4,30	5,08	6,08	7,09	7,97
Heating emission	kW	4,08	5,06	5,84	6,59	8,38	4,77	6,41	7,43	8,49	9,50	6,18	7,32	8,80	10,29	11,54
Dp Cooling	kPa	17,0	24,1	29,9	35,7	50,6	9,0	14,5	18,1	22,1	26,1	13,4	17,4	22,9	28,8	34,1
Dp Heating	kPa	14,1	20,7	26,9	33,4	51,4	7,2	12,2	15,9	20,2	24,7	11,4	15,5	21,6	28,6	35,2
Motor power input	W	70	94	111	129	174	68	100	122	144	166	163	186	213	228	245
Sound power (Lw)	dB(A)	43	49	53	56	62	42	49	54	58	61	48	54	59	63	66
Sound pressure (Lp) ⁽¹⁾	dB(A)	34	40	44	47	53	33	40	45	48	52	39	45	49	53	57

(1) The sound pressure levels are 9 dB (A) lower than the sound power levels, apply to the reverberant field of a 100 m³ room and a reverberation time of 0.5 sec.

Note: for the sound pressure levels with available pressure different from 0 Pa, contact the Sabiana technical sales department.

4 row coil unit - 2 pipe models

The following standard rating conditions are used:

COOLING

Entering air temperature: + 27 °C d.b. + 19 °C w.b.
Water temperature: +7 °C E.W.T. +12 °C L.W.T.

HEATING

Entering air temperature: + 20 °C
Water temperature: +45 °C E.W.T. +40 °C L.W.T.

Available pressure: 0 Pa

MODEL	Speed	CRSL 14					CRSL 24					CRSL 34					CRSL 44				
		1	2	3	4	5	1	2	3	4	5	1	2	3	4	5	1	2	3	4	5
		MIN			MED	MAX	MIN			MED	MAX	MIN			MED	MAX	MIN			MED	MAX
Air flow	m ³ /h	340	400	445	490	535	515	600	660	780	860	500	620	750	960	1115	655	815	955	1080	1340
Cooling total emission	kW	2,39	2,71	2,94	3,21	3,37	3,69	4,16	4,48	5,18	5,45	3,71	4,44	5,17	6,34	6,95	4,41	5,20	5,84	6,53	7,42
Cooling sensible emission	kW	1,71	1,97	2,15	2,33	2,50	2,59	2,96	3,21	3,69	3,99	2,59	3,13	3,69	4,54	5,14	3,18	3,83	4,38	4,85	5,77
Heating emission	kW	2,39	2,78	3,06	3,33	3,60	3,63	4,18	4,56	5,29	5,76	3,57	4,34	5,17	6,43	7,32	4,57	5,56	6,41	7,12	8,57
Dp Cooling	kPa	12,3	15,5	17,9	20,5	23,0	23,8	29,6	33,8	42,4	48,3	18,4	25,4	33,6	47,1	57,4	9,0	12,2	15,0	17,7	23,2
Dp Heating	kPa	11,9	15,5	18,5	21,5	24,8	19,0	24,5	28,6	37,4	43,6	13,7	19,4	26,6	39,4	49,7	7,6	10,8	13,9	16,8	23,5
Motor power input	W	28	35	41	47	55	62	74	82	98	110	50	64	80	106	126	93	110	127	142	175
Sound power (Lw)	dB(A)	40	43	46	48	51	42	46	48	52	55	38	43	48	54	57	45	51	55	58	63
Sound pressure (Lp) ⁽¹⁾	dB(A)	31	34	37	39	42	33	37	39	43	46	29	34	39	44	48	36	42	46	49	54

MODEL	Speed	CRSL 54					CRSL 64					CRSL 74				
		1	2	3	4	5	1	2	3	4	5	1	2	3	4	5
		MIN			MED	MAX	MIN			MED	MAX	MIN			MED	MAX
Air flow	m ³ /h	595	760	895	1030	1375	720	1015	1210	1425	1635	970	1190	1490	1810	2100
Cooling total emission	kW	4,24	5,18	5,88	6,65	8,01	5,10	6,75	7,69	8,80	9,55	6,45	7,53	8,88	10,42	11,29
Cooling sensible emission	kW	2,98	3,69	4,24	4,76	6,02	3,60	4,86	5,62	6,42	7,18	4,61	5,48	6,60	7,74	8,72
Heating emission	kW	4,21	5,26	6,09	6,90	8,84	5,10	6,98	8,16	9,42	10,62	6,70	8,04	9,80	11,58	13,13
Dp Cooling	kPa	9,0	13,0	16,3	19,7	28,5	7,2	11,9	15,1	18,7	22,4	11,2	14,8	19,9	25,4	30,5
Dp Heating	kPa	7,6	11,3	14,7	18,4	28,8	6,2	10,9	14,4	18,6	23,1	10,1	14,0	20,0	27,0	33,9
Motor power input	W	70	94	111	129	174	68	100	122	144	166	163	186	213	228	245
Sound power (Lw)	dB(A)	43	49	53	56	62	42	49	54	58	61	48	54	59	63	66
Sound pressure (Lp) ⁽¹⁾	dB(A)	34	40	44	47	53	33	40	45	48	52	39	45	49	53	57

(1) The sound pressure levels are 9 dB (A) lower than the sound power levels, apply to the reverberant field of a 100 m³ room and a reverberation time of 0.5 sec.

Note: for the sound pressure levels with available pressure different from 0 Pa, contact the Sabiana technical sales department.

3+1 row coil unit - 4 pipe models

The following standard rating conditions are used:

COOLING

Entering air temperature: + 27 °C d.b. + 19 °C w.b.
Water temperature: +7 °C E.W.T. +12 °C L.W.T.

HEATING

Entering air temperature: + 20 °C
Water temperature: +65 °C E.W.T. +55 °C L.W.T.

Available pressure: 0 Pa

MODEL	Speed	CRSL 13+1					CRSL 23+1					CRSL 33+1					CRSL 43+1				
		1	2	3	4	5	1	2	3	4	5	1	2	3	4	5	1	2	3	4	5
		MIN			MED	MAX	MIN			MED	MAX	MIN			MED	MAX	MIN			MED	MAX
Air flow	m ³ /h	340	400	445	490	535	515	600	660	780	860	500	620	750	960	1115	655	815	955	1080	1340
Cooling total emission	kW	2,14	2,41	2,59	2,81	2,93	3,16	3,52	3,75	4,29	4,47	3,36	3,98	4,57	5,54	6,00	4,12	4,83	5,39	6,00	6,74
Cooling sensible emission	kW	1,57	1,78	1,94	2,09	2,24	2,33	2,63	2,84	3,23	3,49	2,44	2,93	3,43	4,19	4,72	3,04	3,65	4,15	4,58	5,43
Heating emission	kW	1,85	2,06	2,21	2,36	2,50	2,65	2,94	3,12	3,48	3,70	2,88	3,33	3,78	4,44	4,87	3,45	3,99	4,41	4,78	5,48
Dp Cooling	kPa	21,7	26,8	30,7	34,6	38,5	15,3	18,6	21,0	25,7	28,8	9,4	12,8	16,5	22,6	27,1	13,8	18,4	22,4	26,1	33,7
Dp Heating	kPa	8,3	10,0	11,4	12,8	14,1	3,8	4,6	5,1	6,2	6,9	4,3	5,6	7,1	9,4	11,2	6,0	7,8	9,3	10,8	13,8
Motor power input	W	28	35	41	47	55	62	74	82	98	110	50	64	80	106	126	93	110	127	142	175
Sound power (Lw)	dB(A)	40	43	46	48	51	42	46	48	52	55	38	43	48	54	57	45	51	55	58	63
Sound pressure (Lp) ⁽¹⁾	dB(A)	31	34	37	39	42	33	37	39	43	46	29	34	39	44	48	36	42	46	49	54

MODEL	Speed	CRSL 53+1					CRSL 63+1					CRSL 73+1				
		1	2	3	4	5	1	2	3	4	5	1	2	3	4	5
		MIN			MED	MAX	MIN			MED	MAX	MIN			MED	MAX
Air flow	m ³ /h	595	760	895	1030	1375	720	1015	1210	1425	1635	970	1190	1490	1810	2100
Cooling total emission	kW	3,98	4,82	5,43	6,11	7,24	4,77	6,19	7,01	7,97	8,56	5,87	6,78	7,90	9,22	9,89
Cooling sensible emission	kW	2,82	3,46	3,95	4,42	5,53	3,44	4,58	5,27	5,99	6,67	4,30	5,08	6,08	7,09	7,97
Heating emission	kW	3,34	3,94	4,39	4,81	5,79	4,05	5,66	5,72	6,35	6,93	4,94	5,66	6,53	7,40	8,12
Dp Cooling	kPa	17,0	24,1	29,9	35,7	50,6	9,0	14,5	18,1	22,1	26,1	13,4	17,4	22,9	28,8	34,1
Dp Heating	kPa	5,1	6,8	8,3	9,8	13,7	8,0	14,7	14,9	18,1	21,1	11,5	14,7	19,0	23,8	28,1
Motor power input	W	70	94	111	129	174	68	100	122	144	166	163	186	213	228	245
Sound power (Lw)	dB(A)	43	49	53	56	62	42	49	54	58	61	48	54	59	63	66
Sound pressure (Lp) ⁽¹⁾	dB(A)	34	40	44	47	53	33	40	45	48	52	39	45	49	53	57

(1) The sound pressure levels are 9 dB (A) lower than the sound power levels, apply to the reverberant field of a 100 m³ room and a reverberation time of 0.5 sec.

Note: for the sound pressure levels with available pressure different from 0 Pa, contact the Sabiana technical sales department.

COOLING EMISSION

3 row coil unit

Entering air temperature: 27 °C - R.H.: 50% - Available pressure: 0 Pa

Model	Speed	WT: 7 / 12 °C				WT: 8 / 13 °C				WT: 10 / 15 °C				WT: 12 / 17 °C					
		Qv m³/h	Pc kW	Ps kW	Qw l/h	Dp(c) kPa	Pc kW	Ps kW	Qw l/h	Dp(c) kPa	Pc kW	Ps kW	Qw l/h	Dp(c) kPa	Pc kW	Ps kW	Qw l/h	Dp(c) kPa	
CRSL 13	5	MAX	535	3,22	2,27	554	44,1	2,89	2,15	497	36,1	2,23	1,94	384	22,5	1,66	1,66	285	13,0
	4	MED	490	3,08	2,12	530	39,6	2,77	2,00	477	32,5	2,15	1,80	369	20,2	1,60	1,56	276	11,6
	3		445	2,84	1,97	488	35,2	2,55	1,86	439	28,9	1,96	1,66	338	17,8	1,45	1,45	249	10,2
	2		400	2,63	1,81	453	30,6	2,37	1,70	408	25,3	1,82	1,52	313	15,6	1,34	1,34	230	8,9
	1	MIN	340	2,33	1,59	402	24,7	2,11	1,49	362	20,4	1,62	1,33	278	12,6	1,18	1,18	204	7,1
CRSL 23	5	MAX	860	4,95	3,54	852	33,2	4,43	3,37	762	27,1	3,43	3,06	590	16,9	2,56	2,56	440	9,9
	4	MED	780	4,74	3,29	815	29,6	4,25	3,12	731	24,1	3,30	2,82	568	15,0	2,48	2,38	427	8,7
	3		660	4,14	2,89	712	24,1	3,71	2,73	638	19,7	2,86	2,45	492	12,2	2,11	2,11	364	7,0
	2		600	3,88	2,68	667	21,4	3,48	2,53	598	17,5	2,67	2,27	460	10,8	1,97	1,97	339	6,2
	1	MIN	515	3,47	2,38	597	17,5	3,12	2,24	537	14,4	2,40	1,99	412	8,9	1,76	1,76	302	5,0
CRSL 33	5	MAX	1115	6,65	4,78	1144	31,4	5,94	4,53	1021	25,5	4,58	4,09	788	15,8	3,41	3,41	586	9,2
	4	MED	960	6,12	4,25	1052	26,2	5,47	4,02	940	21,2	4,24	3,61	729	13,1	3,16	3,06	544	7,6
	3		750	5,05	3,49	869	19,1	4,51	3,29	775	15,5	3,47	2,92	596	9,6	2,54	2,54	437	5,4
	2		620	4,38	2,98	754	14,8	3,92	2,81	675	12,1	3,01	2,48	518	7,4	2,20	2,20	378	4,2
	1	MIN	500	3,69	2,48	634	10,9	3,31	2,33	570	8,9	2,54	2,05	437	5,5	1,84	1,81	317	3,0
CRSL 43	5	MAX	1340	7,49	5,50	1288	38,9	6,69	5,24	1151	31,6	5,19	4,77	892	19,8	3,88	3,88	668	11,6
	4	MED	1080	6,65	4,66	1144	30,2	5,95	4,42	1023	24,5	4,63	3,98	796	15,2	3,47	3,33	597	8,8
	3		955	5,99	4,23	1031	26,0	5,34	4,00	919	21,1	4,11	3,59	708	13,0	3,04	3,04	524	7,5
	2		815	5,37	3,73	923	21,3	4,78	3,52	823	17,3	3,68	3,14	633	10,7	2,70	2,70	465	6,1
	1	MIN	655	4,57	3,12	786	16,0	4,09	2,94	703	13,0	3,14	2,60	540	8,0	2,29	2,29	394	4,5
CRSL 53	5	MAX	1375	7,99	5,63	1374	57,8	7,17	5,33	1234	47,4	5,55	4,85	955	29,6	4,14	4,14	713	17,3
	4	MED	1030	6,70	4,52	1152	40,6	6,05	4,25	1040	33,5	4,68	3,82	805	20,7	3,49	3,36	601	11,9
	3		895	5,94	4,05	1022	33,9	5,36	3,80	922	28,1	4,12	3,40	709	17,3	3,03	3,03	521	9,9
	2		760	5,26	3,55	905	27,3	4,76	3,34	818	22,6	3,65	2,96	629	14,0	2,67	2,64	460	7,9
	1	MIN	595	4,33	2,89	745	19,2	3,92	2,71	675	16,0	3,02	2,39	520	9,9	2,19	2,11	377	5,5
CRSL 63	5	MAX	1635	9,45	6,74	1626	30,1	8,45	6,40	1453	24,5	6,53	5,81	1123	15,2	4,86	4,86	836	8,9
	4	MED	1425	8,76	6,07	1507	25,5	7,86	5,75	1352	20,8	6,09	5,19	1047	12,9	4,55	4,40	782	7,4
	3		1210	7,70	5,34	1324	20,8	6,90	5,05	1187	17,0	5,30	4,52	911	10,5	3,90	3,90	671	6,0
	2		1015	6,79	4,65	1168	16,6	6,10	4,38	1049	13,6	4,67	3,90	804	8,3	3,42	3,42	589	4,7
	1	MIN	720	5,20	3,50	895	10,3	4,70	3,28	808	8,5	3,59	2,90	618	5,2	2,61	2,56	449	2,9
CRSL 73	5		2100	10,96	8,02	1885	39,2	9,79	7,67	1684	31,9	7,61	7,06	1308	20,1	5,73	5,73	985	11,9
	4	MAX	1810	10,20	7,19	1754	33,1	9,14	6,84	1572	26,9	7,12	6,25	1225	16,8	5,39	5,16	927	9,9
	3	MED	1490	8,78	6,21	1510	26,3	7,85	5,88	1350	21,4	6,06	5,33	1042	13,3	4,50	4,50	774	7,7
	2		1190	7,53	5,22	1295	20,0	6,75	4,93	1160	16,3	5,18	4,42	891	10,0	3,82	3,82	657	5,8
	1	MIN	970	6,50	4,44	1118	15,3	5,84	4,18	1005	12,6	4,48	3,72	770	7,7	3,28	3,28	564	4,4

WT: Water temperature
Qv: Air flow
Pc: Cooling total emission
Ps: Cooling sensible emission
Qw: Water flow rate
Dp(c): Dp Cooling

Note: the power absorption (Watt) at p. 23 must be subtracted from the total and sensible cooling emission

Entering air temperature: 26 °C - R.H.: 50% - Available pressure: 0 Pa

Model	Speed		Qv m ³ /h	WT: 7 / 12 °C					WT: 8 / 13 °C					WT: 10 / 15 °C					WT: 12 / 17 °C				
				Pc kW	Ps kW	Qw l/h	Dp(c) kPa	Pc kW	Ps kW	Qw l/h	Dp(c) kPa	Pc kW	Ps kW	Qw l/h	Dp(c) kPa	Pc kW	Ps kW	Qw l/h	Dp(c) kPa				
CRSL 13	5	MAX	535	2,87	2,15	494	35,9	2,54	2,04	438	28,7	1,93	1,84	333	17,4	1,42	1,42	244	9,8				
	4	MED	490	2,76	2,01	474	32,3	2,44	1,90	420	25,8	1,87	1,71	321	15,5	1,37	1,33	236	8,7				
	3		445	2,54	1,86	436	28,7	2,24	1,76	386	22,9	1,70	1,58	292	13,7	1,23	1,23	212	7,7				
	2		400	2,35	1,71	405	25,1	2,08	1,61	358	20,0	1,57	1,44	270	12,0	1,14	1,14	196	6,6				
	1	MIN	340	2,09	1,50	360	20,3	1,85	1,41	318	16,2	1,39	1,25	240	9,6	1,00	1,00	172	5,3				
CRSL 23	5	MAX	860	4,40	3,37	757	26,9	3,90	3,21	671	21,6	2,98	2,91	512	13,1	2,19	2,19	377	7,5				
	4	MED	780	4,23	3,12	727	24,0	3,76	2,97	646	19,2	2,88	2,68	496	11,6	2,14	2,04	367	6,6				
	3		660	3,69	2,74	635	19,6	3,26	2,59	561	15,6	2,47	2,33	426	9,4	1,80	1,80	309	5,2				
	2		600	3,45	2,54	594	17,4	3,05	2,40	525	13,9	2,31	2,14	397	8,3	1,67	1,67	288	4,6				
	1	MIN	515	3,10	2,24	533	14,3	2,74	2,12	472	11,4	2,07	1,88	355	6,8	1,49	1,49	256	3,7				
CRSL 33	5	MAX	1115	5,90	4,54	1015	25,3	5,22	4,30	899	20,2	3,98	3,88	684	12,3	2,91	2,91	500	6,9				
	4	MED	960	5,44	4,03	936	21,1	4,82	3,81	829	16,8	3,68	3,41	633	10,1	2,71	2,60	466	5,7				
	3		750	4,48	3,30	771	15,4	3,96	3,11	682	12,3	2,99	2,76	514	7,3	2,15	2,15	370	4,0				
	2		620	3,90	2,82	671	12,0	3,44	2,65	592	9,6	2,59	2,33	446	5,7	1,85	1,85	319	3,1				
	1	MIN	500	3,29	2,34	566	8,9	2,91	2,19	500	7,0	2,18	1,92	375	4,2	1,55	1,55	267	2,2				
CRSL 43	5	MAX	1340	6,66	5,25	1145	31,5	5,90	5,00	1015	25,2	4,51	4,51	776	15,4	3,33	3,33	573	8,8				
	4	MED	1080	5,92	4,42	1018	24,4	5,25	4,20	904	19,5	4,03	3,78	693	11,8	2,98	2,84	513	6,6				
	3		955	5,31	4,01	914	20,9	4,70	3,79	809	16,7	3,56	3,40	613	10,1	2,59	2,59	445	5,6				
	2		815	4,76	3,53	818	17,2	4,20	3,33	723	13,7	3,17	2,96	546	8,2	2,29	2,29	395	4,5				
	1	MIN	655	4,06	2,95	699	12,9	3,59	2,77	617	10,3	2,70	2,45	465	6,1	1,94	1,94	333	3,3				
CRSL 53	5	MAX	1375	7,14	5,34	1228	47,2	6,32	5,08	1088	37,8	4,82	4,62	829	23,0	3,55	3,55	610	13,1				
	4	MED	1030	6,01	4,26	1034	33,3	5,33	4,03	916	26,5	4,07	3,62	699	15,9	2,99	2,86	514	8,9				
	3		895	5,33	3,82	916	27,9	4,71	3,60	810	22,2	3,56	3,22	612	13,3	2,57	2,57	442	7,3				
	2		760	4,73	3,35	813	22,5	4,18	3,15	719	18,0	3,15	2,79	542	10,7	2,26	2,26	389	5,8				
	1	MIN	595	3,89	2,72	669	15,8	3,46	2,55	594	12,7	2,59	2,25	446	7,5	1,85	1,85	317	4,0				
CRSL 63	5	MAX	1635	8,40	6,40	1446	24,3	7,44	6,09	1279	19,4	5,66	5,53	974	11,8	4,16	4,16	715	6,7				
	4	MED	1425	7,81	5,75	1344	20,6	6,92	5,46	1190	16,4	5,29	4,92	909	9,9	3,90	3,76	671	5,6				
	3		1210	6,86	5,05	1180	16,9	6,06	4,78	1042	13,4	4,58	4,28	787	8,0	3,32	3,32	571	4,5				
	2		1015	6,06	4,39	1042	13,5	5,35	4,14	920	10,7	4,03	3,68	693	6,4	2,90	2,90	499	3,5				
	1	MIN	720	4,67	3,30	803	8,4	4,12	3,09	708	6,7	3,09	2,72	531	4,0	2,19	2,19	377	2,1				
CRSL 73	5		2100	9,74	7,67	1675	31,8	8,64	7,35	1486	25,5	6,64	6,64	1142	15,7	4,94	4,94	849	9,1				
	4	MAX	1810	9,09	6,84	1564	26,8	8,08	6,54	1390	21,5	6,23	5,97	1072	13,1	4,66	4,43	802	7,5				
	3	MED	1490	7,81	5,89	1344	21,3	6,90	5,60	1187	17,0	5,25	5,07	903	10,3	3,85	3,85	662	5,8				
	2		1190	6,71	4,94	1154	16,2	5,92	4,67	1019	12,9	4,48	4,19	771	7,7	3,25	3,25	559	4,3				
	1	MIN	970	5,81	4,19	999	12,5	5,12	3,95	881	9,9	3,86	3,52	664	5,9	2,78	2,78	478	3,2				

WT: Water temperature
Qv: Air flow
Pc: Cooling total emission
Ps: Cooling sensible emission
Qw: Water flow rate
Dp(c): Dp Cooling

Note: the power absorption (Watt) at p. 23 must be subtracted from the total and sensible cooling emission

Entering air temperature: 25 °C - R.H.: 50% - Available pressure: 0 Pa

Model	Speed	Qv m ³ /h	WT: 7 / 12 °C					WT: 8 / 13 °C					WT: 10 / 15 °C					WT: 12 / 17 °C				
			Pc kW	Ps kW	Qw l/h	Dp(c) kPa	Pc kW	Ps kW	Qw l/h	Dp(c) kPa	Pc kW	Ps kW	Qw l/h	Dp(c) kPa	Pc kW	Ps kW	Qw l/h	Dp(c) kPa				
CRSL 13	5	MAX	535	2,53	2,04	436	28,6	2,23	1,94	383	22,6	1,67	1,67	287	13,3	1,20	1,20	206	7,3			
	4	MED	490	2,44	1,90	419	25,7	2,14	1,80	368	20,2	1,61	1,57	278	11,9	1,17	1,12	201	6,4			
	3		445	2,23	1,76	384	22,8	1,96	1,66	337	17,9	1,46	1,46	251	10,5	1,04	1,04	179	5,6			
	2		400	2,07	1,61	357	19,9	1,82	1,52	312	15,6	1,35	1,35	232	9,1	0,95	0,95	164	4,8			
	1	MIN	340	1,84	1,41	317	16,1	1,61	1,33	277	12,6	1,19	1,18	205	7,3	0,84	0,84	144	3,8			
CRSL 23	5	MAX	860	3,89	3,21	669	21,5	3,42	3,05	588	17,0	2,58	2,58	443	10,1	1,92	1,92	330	5,9			
	4	MED	780	3,74	2,96	643	19,1	3,30	2,82	567	15,1	2,50	2,40	430	8,9	1,84	1,75	317	5,0			
	3		660	3,25	2,59	559	15,6	2,85	2,45	491	12,3	2,13	2,13	366	7,2	1,52	1,52	261	3,9			
	2		600	3,04	2,40	523	13,8	2,67	2,27	459	10,9	1,98	1,98	341	6,3	1,41	1,41	242	3,4			
	1	MIN	515	2,73	2,12	469	11,4	2,39	1,99	411	8,9	1,77	1,77	305	5,1	1,25	1,25	214	2,7			
CRSL 33	5	MAX	1115	5,20	4,30	895	20,2	4,58	4,08	787	15,9	3,43	3,43	590	9,4	2,68	2,68	461	6,0			
	4	MED	960	4,81	3,81	827	16,8	4,23	3,60	727	13,2	3,18	3,08	548	7,7	2,43	2,32	417	4,6			
	3		750	3,95	3,11	679	12,3	3,45	2,93	594	9,6	2,56	2,56	441	5,6	1,83	1,83	315	3,0			
	2		620	3,43	2,65	590	9,5	3,00	2,49	516	7,5	2,21	2,19	381	4,3	1,54	1,54	265	2,2			
	1	MIN	500	2,90	2,20	498	7,0	2,53	2,06	435	5,5	1,86	1,80	320	3,1	1,28	1,28	221	1,6			
CRSL 43	5	MAX	1340	5,89	4,99	1012	25,2	5,18	4,75	891	19,9	3,91	3,91	673	11,9	3,21	3,21	552	8,3			
	4	MED	1080	5,24	4,20	901	19,4	4,62	3,98	794	15,3	3,49	3,35	601	9,0	2,74	2,60	472	5,7			
	3		955	4,68	3,80	805	16,7	4,11	3,59	706	13,1	3,07	3,07	527	7,7	2,31	2,31	397	4,6			
	2		815	4,19	3,33	721	13,7	3,67	3,14	631	10,7	2,73	2,73	469	6,2	1,98	1,98	341	3,5			
	1	MIN	655	3,58	2,78	615	10,3	3,13	2,61	538	8,0	2,31	2,30	397	4,6	1,61	1,61	278	2,4			
CRSL 53	5	MAX	1375	6,30	5,08	1084	37,7	5,54	4,84	953	29,8	4,17	4,17	717	17,7	3,01	3,01	518	9,8			
	4	MED	1030	5,31	4,04	913	26,5	4,67	3,82	804	20,8	3,52	3,39	605	12,2	2,54	2,41	437	6,5			
	3		895	4,70	3,61	808	22,2	4,11	3,40	707	17,4	3,05	3,03	525	10,1	2,16	2,16	371	5,4			
	2		760	4,16	3,15	716	17,9	3,65	2,97	627	14,0	2,69	2,63	463	8,1	1,89	1,89	325	4,2			
	1	MIN	595	3,44	2,56	592	12,7	3,01	2,40	517	9,9	2,21	2,11	380	5,6	1,53	1,53	264	2,9			
CRSL 63	5	MAX	1635	7,41	6,09	1274	19,4	6,51	5,79	1119	15,3	4,89	4,89	841	9,1	3,68	3,68	634	5,4			
	4	MED	1425	6,90	5,46	1187	16,4	6,07	5,18	1044	12,9	4,58	4,43	787	7,6	3,37	3,23	580	4,2			
	3		1210	6,03	4,78	1038	13,4	5,28	4,52	909	10,5	3,94	3,94	677	6,1	2,80	2,80	481	3,3			
	2		1015	5,33	4,14	916	10,7	4,66	3,91	802	8,4	3,45	3,45	594	4,8	2,43	2,43	419	2,6			
	1	MIN	720	4,10	3,10	705	6,7	3,58	2,90	616	5,2	2,63	2,55	452	3,0	1,82	1,82	314	1,5			
CRSL 73	5		2100	8,61	7,34	1481	25,4	7,60	7,03	1307	20,2	5,77	5,77	992	12,2	4,64	4,64	798	8,2			
	4	MAX	1810	8,05	6,53	1385	21,4	7,12	6,23	1224	16,9	5,43	5,20	934	10,1	4,24	4,02	730	6,3			
	3	MED	1490	6,88	5,60	1183	17,0	6,04	5,32	1039	13,4	4,53	4,53	779	7,9	3,33	3,33	573	4,5			
	2		1190	5,90	4,67	1015	12,9	5,17	4,42	888	10,1	3,85	3,85	662	5,9	2,74	2,74	471	3,2			
	1	MIN	970	5,11	3,96	879	9,9	4,47	3,73	768	7,8	3,30	3,30	568	4,5	2,33	2,33	401	2,4			

- WT:** Water temperature
- Qv:** Air flow
- Pc:** Cooling total emission
- Ps:** Cooling sensible emission
- Qw:** Water flow rate
- Dp(c):** Dp Cooling

Note: the power absorption (Watt) at p. 23 must be subtracted from the total and sensible cooling emission

4 row coil unit

Entering air temperature: 27 °C - R.H.: 50% - Available pressure: 0 Pa

Model	Speed	Qv m ³ /h	WT: 7 / 12 °C				WT: 8 / 13 °C				WT: 10 / 15 °C				WT: 12 / 17 °C			
			Pc kW	Ps kW	Qw l/h	Dp(c) kPa	Pc kW	Ps kW	Qw l/h	Dp(c) kPa	Pc kW	Ps kW	Qw l/h	Dp(c) kPa	Pc kW	Ps kW	Qw l/h	Dp(c) kPa
CRSL 14	5 MAX	535	3,71	2,54	638	26,6	3,32	2,40	571	21,7	2,55	2,12	439	13,4	1,87	1,87	321	7,5
	4 MED	490	3,52	2,37	605	23,6	3,16	2,23	543	19,3	2,44	1,97	419	11,9	1,79	1,74	308	6,7
	3	445	3,23	2,18	555	20,7	2,89	2,05	498	16,9	2,22	1,81	382	10,4	1,62	1,60	278	5,8
	2	400	2,97	2,00	511	17,8	2,67	1,88	459	14,6	2,05	1,65	352	9,0	1,49	1,45	256	5,0
	1 MIN	340	2,60	1,74	448	14,1	2,35	1,63	403	11,6	1,80	1,43	310	7,2	1,30	1,25	224	4,0
CRSL 24	5 MAX	860	5,99	4,09	1031	55,2	5,40	3,85	929	45,6	4,16	3,41	716	28,3	3,06	3,03	526	16,1
	4 MED	780	5,67	3,77	975	48,4	5,12	3,55	881	40,1	3,97	3,14	683	24,8	2,93	2,78	505	14,0
	3	660	4,90	3,28	842	38,4	4,43	3,08	762	31,9	3,41	2,72	587	19,8	2,49	2,39	428	11,1
	2	600	4,54	3,03	781	33,5	4,12	2,84	708	28,0	3,17	2,50	545	17,3	2,31	2,19	397	9,7
	1 MIN	515	4,01	2,65	690	26,8	3,64	2,49	627	22,4	2,81	2,18	484	14,0	2,04	1,91	351	7,8
CRSL 34	5 MAX	1115	7,64	5,24	1314	65,8	6,86	4,93	1181	54,1	5,30	4,39	911	33,6	3,89	3,89	669	19,1
	4 MED	960	6,94	4,63	1193	53,8	6,26	4,36	1077	44,4	4,85	3,86	833	27,5	3,57	3,42	615	15,5
	3	750	5,64	3,77	970	38,1	5,11	3,54	878	31,7	3,93	3,11	676	19,6	2,86	2,73	492	11,0
	2	620	4,82	3,19	829	28,7	4,37	2,99	752	24,0	3,37	2,62	580	14,9	2,44	2,29	420	8,3
	1 MIN	500	4,01	2,64	690	20,7	3,65	2,48	628	17,3	2,82	2,16	486	10,8	2,04	1,88	351	6,0
CRSL 44	5 MAX	1340	8,25	5,88	1419	26,9	7,35	5,57	1265	21,7	5,67	5,00	975	13,5	4,19	4,19	721	7,8
	4 MED	1080	7,23	4,95	1244	20,5	6,47	4,67	1113	16,6	5,00	4,17	861	10,2	3,72	3,57	639	5,8
	3	955	6,49	4,48	1116	17,5	5,79	4,22	996	14,1	4,44	3,75	764	8,7	3,26	3,26	560	4,9
	2	815	5,77	3,93	992	14,1	5,16	3,70	887	11,5	3,95	3,27	680	7,0	2,88	2,88	496	4,0
	1 MIN	655	4,87	3,27	837	10,4	4,37	3,07	751	8,5	3,35	2,70	576	5,2	2,43	2,37	418	2,9
CRSL 54	5 MAX	1375	8,84	6,14	1521	32,8	7,93	5,80	1364	26,8	6,11	5,20	1050	16,6	4,51	4,51	775	9,5
	4 MED	1030	7,30	4,87	1255	22,5	6,58	4,59	1132	18,5	5,08	4,07	875	11,4	3,75	3,61	646	6,4
	3	895	6,44	4,34	1108	18,6	5,81	4,08	1000	15,3	4,46	3,60	767	9,4	3,25	3,19	559	5,3
	2	760	5,66	3,78	974	14,7	5,13	3,55	882	12,2	3,93	3,13	677	7,5	2,85	2,75	491	4,2
	1 MIN	595	4,61	3,05	794	10,2	4,18	2,87	720	8,5	3,22	2,51	554	5,3	2,33	2,19	400	2,9
CRSL 64	5 MAX	1635	10,51	7,28	1807	25,8	9,41	6,88	1618	21,0	7,23	6,16	1243	13,0	5,32	5,32	916	7,4
	4 MED	1425	9,67	6,53	1663	21,6	8,68	6,15	1494	17,7	6,69	5,48	1150	10,8	4,94	4,80	850	6,1
	3	1210	8,43	5,72	1450	17,3	7,58	5,38	1304	14,2	5,80	4,77	998	8,7	4,23	4,23	728	4,9
	2	1015	7,37	4,95	1268	13,6	6,64	4,65	1143	11,2	5,09	4,10	875	6,9	3,70	3,62	636	3,8
	1 MIN	720	5,54	3,67	953	8,1	5,02	3,45	864	6,8	3,85	3,02	662	4,2	2,78	2,64	478	2,3
CRSL 74	5 MAX	2100	12,49	8,84	2148	35,2	11,15	8,39	1919	28,6	8,61	7,59	1481	17,8	6,40	6,40	1101	10,3
	4 MED	1810	11,51	7,89	1980	29,3	10,32	7,46	1776	23,9	7,99	6,70	1374	14,7	5,97	5,74	1026	8,5
	3	1490	9,83	6,76	1691	22,9	8,81	6,38	1516	18,7	6,76	5,69	1163	11,5	4,97	4,97	854	6,5
	2	1190	8,33	5,64	1433	17,0	7,48	5,30	1287	13,9	5,73	4,70	986	8,5	4,18	4,17	719	4,8
	1 MIN	970	7,11	4,76	1223	12,8	6,42	4,47	1104	10,6	4,91	3,94	844	6,5	3,57	3,47	613	3,6

WT: Water temperature
Qv: Air flow
Pc: Cooling total emission
Ps: Cooling sensible emission
Qw: Water flow rate
Dp(c): Dp Cooling

Note: the power absorption (Watt) at p. 23 must be subtracted from the total and sensible cooling emission

Entering air temperature: 26 °C - R.H.: 50% - Available pressure: 0 Pa

Model	Speed	Qv m ³ /h	WT: 7 / 12 °C				WT: 8 / 13 °C				WT: 10 / 15 °C				WT: 12 / 17 °C				
			Pc kW	Ps kW	Qw l/h	Dp(c) kPa	Pc kW	Ps kW	Qw l/h	Dp(c) kPa	Pc kW	Ps kW	Qw l/h	Dp(c) kPa	Pc kW	Ps kW	Qw l/h	Dp(c) kPa	
CRSL 14	5	MAX	535	3,30	2,40	567	21,5	2,91	2,26	501	17,2	2,20	2,00	378	10,2	1,58	1,58	271	5,6
	4	MED	490	3,14	2,23	540	19,1	2,78	2,10	478	15,3	2,11	1,85	362	9,1	1,52	1,47	261	4,9
	3		445	2,88	2,06	495	16,8	2,54	1,93	437	13,4	1,91	1,70	329	8,0	1,36	1,36	234	4,3
	2		400	2,65	1,88	456	14,5	2,34	1,76	403	11,6	1,76	1,55	303	6,9	1,25	1,25	215	3,7
	1	MIN	340	2,33	1,64	401	11,5	2,06	1,53	355	9,2	1,55	1,34	266	5,4	1,09	1,09	188	2,9
CRSL 24	5	MAX	860	5,36	3,86	923	45,3	4,75	3,63	817	36,2	3,59	3,22	618	21,7	2,59	2,59	445	11,9
	4	MED	780	5,09	3,56	876	39,8	4,52	3,35	778	31,8	3,44	2,95	591	19,0	2,49	2,39	428	10,3
	3		660	4,40	3,10	757	31,7	3,90	2,90	670	25,4	2,94	2,55	505	15,1	2,09	2,09	360	8,1
	2		600	4,09	2,86	703	27,7	3,62	2,67	623	22,2	2,73	2,34	469	13,2	1,93	1,93	333	7,1
	1	MIN	515	3,62	2,50	622	22,2	3,21	2,34	552	17,9	2,42	2,04	415	10,6	1,70	1,70	293	5,6
CRSL 34	5	MAX	1115	6,82	4,95	1174	53,8	6,04	4,66	1039	42,9	4,57	4,14	786	25,8	3,30	3,30	567	14,2
	4	MED	960	6,22	4,38	1071	44,2	5,52	4,11	949	35,2	4,19	3,63	721	21,1	3,03	2,93	522	11,4
	3		750	5,07	3,55	872	31,5	4,49	3,33	772	25,2	3,38	2,92	581	15,0	2,40	2,40	413	8,0
	2		620	4,34	3,01	746	23,8	3,85	2,81	663	19,1	2,90	2,45	498	11,3	2,04	2,04	351	6,0
	1	MIN	500	3,62	2,49	622	17,1	3,22	2,33	555	13,9	2,42	2,02	417	8,2	1,70	1,70	292	4,3
CRSL 44	5	MAX	1340	7,31	5,58	1258	21,6	6,47	5,28	1112	17,3	4,91	4,74	844	10,4	3,57	3,57	615	5,8
	4	MED	1080	6,43	4,68	1106	16,5	5,70	4,42	981	13,1	4,34	3,93	746	7,8	3,17	3,03	546	4,3
	3		955	5,76	4,23	990	14,1	5,08	3,98	875	11,2	3,83	3,53	659	6,7	2,76	2,76	474	3,7
	2		815	5,12	3,71	881	11,4	4,53	3,48	779	9,1	3,40	3,07	585	5,4	2,43	2,43	418	2,9
	1	MIN	655	4,34	3,08	746	8,4	3,83	2,89	659	6,7	2,88	2,53	495	4,0	2,04	2,04	351	2,1
CRSL 54	5	MAX	1375	7,89	5,82	1356	26,7	6,97	5,50	1199	21,3	5,28	4,92	908	12,8	3,83	3,83	659	7,1
	4	MED	1030	6,54	4,60	1125	18,4	5,79	4,33	997	14,6	4,40	3,83	756	8,7	3,19	3,06	549	4,8
	3		895	5,78	4,09	993	15,2	5,11	3,85	878	12,1	3,84	3,39	660	7,2	2,74	2,74	471	3,9
	2		760	5,09	3,57	876	12,1	4,50	3,34	774	9,7	3,38	2,93	581	5,7	2,40	2,40	412	3,1
	1	MIN	595	4,15	2,88	714	8,4	3,68	2,69	633	6,7	2,76	2,35	474	4,0	1,94	1,94	334	2,1
CRSL 64	5	MAX	1635	9,35	6,89	1609	20,9	8,26	6,51	1420	16,6	6,24	5,82	1074	10,0	4,52	4,52	778	5,5
	4	MED	1425	8,63	6,17	1485	17,6	7,64	5,81	1313	13,9	5,79	5,17	996	8,3	4,21	4,07	724	4,6
	3		1210	7,53	5,39	1296	14,2	6,65	5,07	1144	11,3	4,99	4,49	859	6,7	3,58	3,58	615	3,6
	2		1015	6,60	4,66	1135	11,2	5,82	4,37	1002	8,9	4,37	3,85	752	5,2	3,11	3,11	535	2,8
	1	MIN	720	4,98	3,46	857	6,7	4,41	3,23	758	5,4	3,30	2,82	567	3,2	2,32	2,32	400	1,7
CRSL 74	5		2100	11,10	8,40	1910	28,4	9,82	7,98	1689	22,7	7,47	7,22	1285	13,8	5,46	5,46	940	7,8
	4	MAX	1810	10,27	7,47	1766	23,7	9,10	7,07	1564	18,9	6,94	6,35	1194	11,4	5,11	4,89	880	6,3
	3	MED	1490	8,76	6,39	1507	18,6	7,73	6,03	1330	14,8	5,83	5,38	1003	8,8	4,21	4,21	724	4,8
	2		1190	7,44	5,32	1279	13,8	6,56	5,00	1129	11,0	4,93	4,42	848	6,5	3,53	3,53	607	3,5
	1	MIN	970	6,37	4,49	1096	10,5	5,63	4,21	968	8,3	4,22	3,70	725	4,9	3,00	3,00	515	2,6

- WT:** Water temperature
- Qv:** Air flow
- Pc:** Cooling total emission
- Ps:** Cooling sensible emission
- Qw:** Water flow rate
- Dp(c):** Dp Cooling

Note: the power absorption (Watt) at p. 23 must be subtracted from the total and sensible cooling emission

Entering air temperature: 25 °C - R.H.: 50% - Available pressure: 0 Pa

Model	Speed		Qv m ³ /h	WT: 7 / 12 °C				WT: 8 / 13 °C				WT: 10 / 15 °C				WT: 12 / 17 °C			
				Pc kW	Ps kW	Qw l/h	Dp(c) kPa	Pc kW	Ps kW	Qw l/h	Dp(c) kPa	Pc kW	Ps kW	Qw l/h	Dp(c) kPa	Pc kW	Ps kW	Qw l/h	Dp(c) kPa
CRSL 14	5	MAX	535	2,90	2,26	500	17,1	2,54	2,13	437	13,4	1,88	1,88	324	7,7	1,32	1,32	226	4,0
	4	MED	490	2,77	2,10	476	15,2	2,43	1,97	418	11,9	1,81	1,74	310	6,8	1,27	1,23	219	3,5
	3		445	2,53	1,94	435	13,4	2,21	1,82	381	10,5	1,63	1,60	281	6,0	1,13	1,13	195	3,1
	2		400	2,33	1,77	401	11,5	2,04	1,66	351	9,0	1,50	1,45	258	5,1	1,03	1,03	178	2,6
	1	MIN	340	2,05	1,54	353	9,2	1,79	1,43	309	7,2	1,32	1,25	226	4,1	0,90	0,90	155	2,0
CRSL 24	5	MAX	860	4,73	3,64	814	36,1	4,15	3,42	714	28,4	3,08	3,03	530	16,5	2,16	2,16	371	8,6
	4	MED	780	4,50	3,35	774	31,7	3,96	3,15	681	24,9	2,95	2,77	508	14,4	2,09	1,99	360	7,4
	3		660	3,88	2,91	667	25,3	3,40	2,73	585	19,8	2,51	2,39	431	11,4	1,73	1,73	298	5,8
	2		600	3,60	2,68	620	22,1	3,16	2,51	543	17,4	2,32	2,19	400	9,9	1,60	1,60	275	5,0
	1	MIN	515	3,19	2,35	549	17,8	2,80	2,19	481	14,0	2,06	1,91	354	7,9	1,40	1,40	241	4,0
CRSL 34	5	MAX	1115	6,02	4,67	1036	42,9	5,28	4,39	908	33,7	3,92	3,89	674	19,5	2,76	2,76	474	10,3
	4	MED	960	5,50	4,12	946	35,2	4,83	3,87	831	27,6	3,61	3,41	620	15,9	2,55	2,44	438	8,2
	3		750	4,47	3,34	769	25,1	3,91	3,12	673	19,7	2,88	2,73	496	11,2	1,98	1,98	341	5,7
	2		620	3,83	2,82	659	19,0	3,36	2,64	577	14,9	2,46	2,29	424	8,5	1,68	1,68	289	4,2
	1	MIN	500	3,21	2,33	551	13,8	2,81	2,18	483	10,8	2,06	1,88	354	6,1	1,38	1,38	238	3,0
CRSL 44	5	MAX	1340	6,44	5,28	1108	17,2	5,65	4,99	972	13,5	4,23	4,23	727	8,0	3,26	3,26	561	4,9
	4	MED	1080	5,68	4,42	976	13,1	4,99	4,16	858	10,3	3,74	3,60	644	6,0	2,79	2,65	480	3,4
	3		955	5,06	3,99	871	11,2	4,43	3,75	763	8,8	3,28	3,28	565	5,0	2,35	2,35	404	2,7
	2		815	4,51	3,49	775	9,0	3,94	3,28	678	7,1	2,91	2,89	500	4,1	2,02	2,02	348	2,1
	1	MIN	655	3,82	2,90	656	6,7	3,34	2,71	574	5,2	2,45	2,37	421	3,0	1,69	1,69	290	1,5
CRSL 54	5	MAX	1375	6,94	5,50	1194	21,2	6,09	5,20	1048	16,7	4,54	4,54	781	9,8	3,22	3,22	555	5,2
	4	MED	1030	5,77	4,34	993	14,6	5,07	4,07	872	11,4	3,78	3,60	650	6,6	2,69	2,56	462	3,4
	3		895	5,08	3,85	874	12,1	4,44	3,61	764	9,5	3,28	3,18	564	5,4	2,28	2,28	392	2,8
	2		760	4,48	3,35	770	9,6	3,92	3,14	674	7,5	2,88	2,75	495	4,3	1,98	1,98	341	2,2
	1	MIN	595	3,66	2,70	630	6,7	3,20	2,52	551	5,2	2,34	2,19	403	3,0	1,60	1,60	275	1,5
CRSL 64	5	MAX	1635	8,23	6,52	1415	16,6	7,21	6,15	1239	13,0	5,36	5,36	922	7,6	3,81	3,81	655	4,0
	4	MED	1425	7,60	5,82	1308	13,9	6,67	5,48	1147	10,9	4,98	4,84	857	6,3	3,55	3,41	611	3,3
	3		1210	6,62	5,08	1138	11,2	5,78	4,77	995	8,8	4,27	4,22	735	5,0	2,99	2,99	514	2,6
	2		1015	5,80	4,38	997	8,8	5,07	4,11	871	6,9	3,72	3,61	640	3,9	2,58	2,58	444	2,0
	1	MIN	720	4,38	3,24	754	5,3	3,83	3,03	659	4,2	2,80	2,64	482	2,4	1,91	1,91	329	1,2
CRSL 74	5		2100	9,79	7,98	1684	22,7	8,59	7,58	1478	17,9	6,45	6,45	1109	10,5	4,82	4,82	829	6,2
	4	MAX	1810	9,06	7,08	1559	18,9	7,97	6,70	1372	14,8	6,01	5,78	1033	8,7	4,40	4,17	757	4,8
	3	MED	1490	7,70	6,04	1325	14,7	6,75	5,70	1160	11,5	5,00	5,00	860	6,7	3,53	3,53	608	3,5
	2		1190	6,54	5,01	1125	11,0	5,71	4,71	983	8,6	4,21	4,16	725	4,9	2,95	2,95	507	2,6
	1	MIN	970	5,60	4,22	963	8,3	4,89	3,95	842	6,5	3,59	3,47	618	3,7	2,49	2,49	428	1,9

WT: Water temperature
Qv: Air flow
Pc: Cooling total emission
Ps: Cooling sensible emission
Qw: Water flow rate
Dp(c): Dp Cooling

Note: the power absorption (Watt) at p. 23 must be subtracted from the total and sensible cooling emission

HEATING EMISSION

3 row coil unit

Entering air temperature: 20 °C - Available pressure: 0 Pa

Model	Speed		WT: 70 / 60 °C			WT: 60 / 50 °C			WT: 55 / 45 °C			WT: 50 / 40 °C			WT: 50 / 45 °C			WT: 45 / 40 °C		
			Ph kW	Qw l/h	Dp(h) kPa	Ph kW	Qw l/h	Dp(h) kPa	Ph kW	Qw l/h	Dp(h) kPa	Ph kW	Qw l/h	Dp(h) kPa	Ph kW	Qw l/h	Dp(h) kPa	Ph kW	Qw l/h	Dp(h) kPa
CRSL 13	5	MAX	6,67	574	37,7	5,12	440	24,2	4,34	374	18,4	3,57	307	13,1	4,09	703	57,8	3,31	569	40,3
	4	MED	6,19	532	33,0	4,76	409	21,3	4,04	348	16,1	3,32	285	11,5	3,79	652	50,5	3,08	530	35,4
	3		5,71	491	28,5	4,39	378	18,4	3,73	320	13,9	3,06	263	9,9	3,50	601	43,6	2,84	489	30,6
	2		5,21	448	24,2	4,01	345	15,6	3,41	293	11,9	2,80	240	8,5	3,19	549	37,1	2,59	446	26,0
	1	MIN	4,53	390	18,8	3,48	299	12,1	2,96	255	9,2	2,44	210	6,6	2,77	477	28,7	2,25	388	20,2
CRSL 23	5	MAX	10,41	896	27,4	7,99	687	17,6	6,78	583	13,3	5,55	478	9,5	6,38	1098	42,0	5,18	891	29,4
	4	MED	9,62	828	23,8	7,39	636	15,3	6,26	539	11,6	5,13	441	8,2	5,90	1014	36,5	4,78	822	25,4
	3		8,38	721	18,5	6,43	553	11,9	5,46	469	9,0	4,48	386	6,4	5,13	883	28,4	4,16	715	19,8
	2		7,72	664	16,0	5,94	511	10,3	5,03	433	7,8	4,13	356	5,6	4,73	814	24,5	3,84	660	17,2
	1	MIN	6,78	583	12,7	5,21	448	8,1	4,42	381	6,2	3,63	312	4,4	4,15	713	19,3	3,37	580	13,6
CRSL 33	5	MAX	14,09	1211	26,2	10,77	926	16,7	9,14	786	12,7	7,49	644	9,0	8,63	1484	40,2	6,99	1202	28,0
	4	MED	12,41	1067	20,9	9,53	819	13,4	8,07	694	10,1	6,62	569	7,2	7,60	1307	31,9	6,16	1059	22,3
	3		10,04	864	14,3	7,72	664	9,2	6,55	563	7,0	5,38	462	5,0	6,14	1057	21,8	4,98	857	15,2
	2		8,48	730	10,5	6,53	561	6,8	5,54	476	5,1	4,55	392	3,7	5,20	894	16,1	4,22	726	11,3
	1	MIN	6,99	601	7,4	5,38	463	4,8	4,57	393	3,6	3,76	323	2,6	4,28	737	11,4	3,48	598	8,0
CRSL 43	5	MAX	16,36	1407	34,3	12,52	1077	22,0	10,59	911	16,5	8,68	746	11,8	10,03	1724	52,6	8,11	1395	36,6
	4	MED	13,72	1180	25,0	10,50	903	16,0	8,91	766	12,1	7,29	627	8,6	8,40	1445	38,3	6,80	1170	26,7
	3		12,36	1063	20,7	9,48	815	13,3	8,03	690	10,0	6,58	566	7,1	7,58	1303	31,8	6,14	1056	22,2
	2		10,80	929	16,3	8,28	712	10,4	7,02	604	7,9	5,76	495	5,6	6,61	1137	24,9	5,36	922	17,4
	1	MIN	8,92	767	11,5	6,84	589	7,4	5,81	499	5,6	4,77	410	4,0	5,46	938	17,6	4,43	762	12,3
CRSL 53	5	MAX	16,88	1451	48,1	12,96	1114	30,9	10,99	945	23,4	9,03	776	16,7	10,33	1776	73,5	8,38	1442	51,4
	4	MED	13,25	1139	31,1	10,19	877	20,1	8,66	745	15,2	7,12	612	10,9	8,11	1395	47,6	6,59	1134	33,4
	3		11,75	1010	25,0	9,05	778	16,2	7,67	659	12,2	6,31	543	8,8	7,19	1237	38,3	5,84	1005	26,9
	2		10,18	875	19,3	7,84	674	12,5	6,67	574	9,5	5,49	472	6,8	6,24	1073	29,7	5,06	871	20,7
	1	MIN	8,19	704	13,1	6,31	543	8,5	5,37	462	6,4	4,43	381	4,6	5,01	862	20,0	4,08	702	14,1
CRSL 63	5	MAX	19,13	1645	23,1	14,64	1259	14,8	12,41	1067	11,2	10,17	875	8,0	11,72	2015	35,5	9,50	1633	24,7
	4	MED	17,11	1472	18,9	13,13	1129	12,2	11,13	957	9,2	9,12	784	6,5	10,49	1805	29,1	8,49	1460	20,2
	3		14,97	1287	14,9	11,47	986	9,5	9,73	837	7,2	7,98	686	5,1	9,16	1576	22,8	7,43	1277	15,9
	2		12,91	1110	11,4	9,91	852	7,3	8,39	722	5,5	6,89	593	4,0	7,90	1359	17,5	6,41	1103	12,2
	1	MIN	9,59	825	6,7	7,37	634	4,3	6,26	538	3,3	5,15	443	2,3	5,87	1009	10,2	4,77	821	7,2
CRSL 73	5		23,29	2003	33,0	17,83	1534	21,1	15,10	1298	15,9	12,34	1061	11,3	14,26	2454	50,5	11,54	1985	35,2
	4	MAX	20,73	1783	26,8	15,87	1365	17,1	13,45	1157	12,9	11,01	947	9,2	12,70	2185	41,0	10,29	1770	28,6
	3	MED	17,75	1526	20,2	13,61	1171	13,0	11,53	992	9,8	9,45	812	7,0	10,87	1870	31,0	8,80	1514	21,6
	2		14,76	1269	14,5	11,31	973	9,3	9,59	825	7,0	7,87	677	5,0	9,04	1556	22,2	7,32	1259	15,5
	1	MIN	12,41	1068	10,6	9,52	819	6,8	8,09	696	5,2	6,65	572	3,7	7,60	1307	16,3	6,18	1062	11,4

WT: Water temperature
 Ph: Heating emission
 Qw: Water flow rate
 Dp(h): Dp Heating

4 row coil unit

Entering air temperature: 20 °C - Available pressure: 0 Pa

Model	Speed	Qv m ³ /h	WT: 70 / 60 °C				WT: 60 / 50 °C				WT: 55 / 45 °C				WT: 50 / 40 °C				WT: 50 / 45 °C				WT: 45 / 40 °C			
			Ph kW	Qw l/h	Dp(h) kPa	Ph kW	Qw l/h	Dp(h) kPa	Ph kW	Qw l/h	Dp(h) kPa	Ph kW	Qw l/h	Dp(h) kPa	Ph kW	Qw l/h	Dp(h) kPa	Ph kW	Qw l/h	Dp(h) kPa	Ph kW	Qw l/h	Dp(h) kPa			
CRSL 14	5	MAX	535	7,23	622	23,1	5,56	478	14,9	4,73	407	11,3	3,89	334	8,1	4,43	763	35,4	3,60	619	24,8					
	4	MED	490	6,71	577	20,2	5,15	443	12,9	4,38	377	9,9	3,60	309	7,1	4,10	705	30,8	3,33	572	21,5					
	3		445	6,15	529	17,2	4,73	407	11,1	4,02	345	8,4	3,30	284	6,0	3,76	646	26,3	3,06	526	18,5					
	2		400	5,58	480	14,5	4,29	369	9,4	3,65	314	7,1	3,01	259	5,1	3,42	588	22,2	2,78	477	15,5					
	1	MIN	340	4,81	414	11,1	3,70	319	7,2	3,16	271	5,5	2,60	223	3,9	2,95	507	17,0	2,39	412	11,9					
CRSL 24	5	MAX	860	11,57	995	40,6	8,92	767	26,3	7,59	652	20,0	6,25	537	14,4	7,08	1217	62,0	5,76	990	43,6					
	4	MED	780	10,62	914	34,8	8,17	703	22,5	6,95	598	17,1	5,73	493	12,3	6,50	1117	53,2	5,29	909	37,4					
	3		660	9,14	786	26,6	7,05	606	17,2	6,00	516	13,1	4,95	426	9,4	5,60	963	40,7	4,56	784	28,6					
	2		600	8,39	721	22,8	6,47	557	14,8	5,51	474	11,3	4,55	391	8,1	5,14	884	34,9	4,18	720	24,5					
	1	MIN	515	7,30	628	17,7	5,62	484	11,5	4,79	412	8,7	3,95	340	6,3	4,46	767	27,0	3,63	625	19,0					
CRSL 34	5	MAX	1115	14,71	1265	46,3	11,33	974	30,0	9,63	828	22,8	7,93	682	16,3	9,01	1550	71,0	7,32	1259	49,7					
	4	MED	960	12,92	1111	36,7	9,95	856	23,7	8,47	728	18,1	6,97	600	13,0	7,91	1361	56,1	6,43	1105	39,4					
	3		750	10,39	893	24,8	7,99	687	16,0	6,80	585	12,2	5,61	483	8,8	6,35	1092	37,8	5,17	889	26,6					
	2		620	8,70	748	18,0	6,72	578	11,7	5,72	492	8,9	4,71	405	6,4	5,33	917	27,6	4,34	746	19,4					
	1	MIN	500	7,15	615	12,7	5,53	475	8,2	4,71	405	6,3	3,88	334	4,5	4,38	754	19,4	3,57	614	13,6					
CRSL 44	5	MAX	1340	17,24	1482	21,9	13,23	1138	14,1	11,20	964	10,6	9,18	790	7,6	10,58	1820	33,7	8,57	1475	23,5					
	4	MED	1080	14,35	1234	15,8	11,03	948	10,1	9,35	804	7,7	7,66	658	5,5	8,78	1511	24,1	7,12	1225	16,8					
	3		955	12,88	1108	13,0	9,90	852	8,4	8,40	723	6,3	6,90	593	4,5	7,90	1358	19,9	6,41	1102	13,9					
	2		815	11,21	964	10,1	8,60	740	6,5	7,30	628	4,9	6,00	516	3,5	6,85	1179	15,4	5,56	957	10,8					
	1	MIN	655	9,20	791	7,1	7,07	608	4,6	6,00	516	3,5	4,94	425	2,5	5,62	967	10,8	4,57	786	7,6					
CRSL 54	5	MAX	1375	17,82	1533	27,0	13,68	1177	17,3	11,62	1000	13,2	9,53	820	9,4	10,91	1877	41,3	8,84	1521	28,8					
	4	MED	1030	13,86	1192	17,2	10,67	917	11,1	9,06	779	8,4	7,45	641	6,0	8,50	1462	26,3	6,90	1186	18,4					
	3		895	12,25	1053	13,7	9,42	810	8,9	8,02	690	6,7	6,59	567	4,8	7,49	1288	21,0	6,09	1048	14,7					
	2		760	10,57	909	10,5	8,14	700	6,8	6,92	595	5,2	5,70	490	3,7	6,46	1112	16,1	5,26	905	11,3					
	1	MIN	595	8,43	725	7,0	6,51	560	4,6	5,54	476	3,5	4,57	393	2,5	5,17	889	10,7	4,21	724	7,6					
CRSL 64	5	MAX	1635	21,35	1836	21,6	16,40	1410	13,9	13,91	1197	10,5	11,43	983	7,5	13,09	2251	33,0	10,62	1827	23,1					
	4	MED	1425	18,99	1633	17,5	14,57	1253	11,2	12,37	1064	8,5	10,16	873	6,1	11,62	1998	26,7	9,42	1621	18,6					
	3		1210	16,44	1414	13,5	12,63	1086	8,7	10,73	923	6,6	8,81	758	4,7	10,05	1729	20,6	8,16	1403	14,4					
	2		1015	14,02	1206	10,1	10,79	928	6,5	9,16	788	5,0	7,55	650	3,6	8,59	1478	15,5	6,98	1200	10,9					
	1	MIN	720	10,25	882	5,8	7,90	679	3,7	6,71	577	2,8	5,53	475	2,0	6,27	1078	8,8	5,10	878	6,2					
CRSL 74	5		2100	26,39	2270	31,6	20,23	1740	20,2	17,17	1477	15,3	14,06	1209	10,9	16,17	2781	48,4	13,13	2258	33,9					
	4	MAX	1810	23,31	2005	25,3	17,87	1536	16,2	15,18	1305	12,3	12,44	1070	8,7	14,29	2458	38,7	11,58	1992	27,0					
	3	MED	1490	19,70	1695	18,7	15,14	1302	12,0	12,83	1104	9,1	10,56	908	6,5	12,09	2079	28,6	9,80	1686	20,0					
	2		1190	16,17	1390	13,1	12,43	1069	8,4	10,57	909	6,4	8,69	748	4,6	9,91	1705	20,0	8,04	1384	14,0					
	1	MIN	970	13,46	1158	9,4	10,36	891	6,1	8,80	757	4,6	7,24	622	3,3	8,25	1419	14,4	6,70	1152	10,1					

WT: Water temperature
Qv: Air flow
Ph: Heating emission
Qw: Water flow rate
Dp(h): Dp Heating

1 row heating additional coil unit

For 3 or 4 row version

Entering air temperature: 20 °C - Available pressure: 0 Pa

Model	Speed		Qv m ³ /h	WT: 80 / 70 °C			WT: 75 / 65 °C			WT: 70 / 60 °C			WT: 65 / 55 °C			WT: 60 / 50 °C			WT: 55 / 45 °C		
				Ph kW	Qw l/h	Dp(h) kPa	Ph kW	Qw l/h	Dp(h) kPa	Ph kW	Qw l/h	Dp(h) kPa	Ph kW	Qw l/h	Dp(h) kPa	Ph kW	Qw l/h	Dp(h) kPa	Ph kW	Qw l/h	Dp(h) kPa
CRSL 13+1	5	MAX	535	3,53	303	25,1	3,18	274	21,2	2,84	244	17,5	2,50	215	14,1	2,15	185	11,0	1,81	155	8,2
	4	MED	490	3,33	286	22,6	3,01	259	19,1	2,68	231	15,8	2,36	203	12,8	2,03	175	9,9	1,71	147	7,4
	3		445	3,13	269	20,2	2,83	243	17,1	2,52	217	14,1	2,21	190	11,4	1,91	164	8,9	1,60	138	6,6
	2		400	2,91	251	17,8	2,64	227	15,1	2,35	202	12,5	2,06	178	10,0	1,78	153	7,8	1,50	129	5,8
	1	MIN	340	2,62	225	14,7	2,36	203	12,4	2,11	181	10,3	1,85	159	8,3	1,60	137	6,4	1,34	116	4,8
CRSL 23+1	5	MAX	860	5,28	454	12,5	4,75	408	10,5	4,22	363	8,6	3,70	318	6,9	3,17	273	5,3	2,64	227	3,9
	4	MED	780	4,96	427	11,2	4,46	384	9,4	3,97	341	7,7	3,48	299	6,2	2,98	256	4,8	2,49	214	3,5
	3		660	4,46	383	9,2	4,01	345	7,8	3,57	307	6,4	3,12	269	5,1	2,68	230	3,9	2,24	192	2,9
	2		600	4,19	360	8,2	3,77	324	6,9	3,36	289	5,7	2,94	253	4,6	2,52	217	3,5	2,10	181	2,6
	1	MIN	515	3,78	325	6,9	3,41	293	5,8	3,03	261	4,8	2,65	228	3,8	2,28	196	2,9	1,90	164	2,2
CRSL 33+1	5	MAX	1115	6,92	595	20,0	6,24	537	16,9	5,55	478	13,9	4,87	419	11,2	4,19	361	8,7	3,51	302	6,4
	4	MED	960	6,28	540	16,8	5,67	487	14,2	5,06	435	11,7	4,44	382	9,4	3,82	328	7,3	3,20	275	5,4
	3		750	5,35	460	12,6	4,83	416	10,6	4,31	370	8,8	3,78	325	7,1	3,25	280	5,5	2,73	235	4,1
	2		620	4,71	405	10,0	4,25	366	8,5	3,79	326	7,0	3,33	287	5,6	2,87	247	4,4	2,41	207	3,2
	1	MIN	500	4,08	351	7,7	3,67	316	6,5	3,28	282	5,4	2,88	248	4,3	2,48	213	3,4	2,08	179	2,5
CRSL 43+1	5	MAX	1340	7,78	669	24,7	7,01	603	20,8	6,24	537	17,2	5,48	471	13,8	4,71	405	10,7	3,94	339	7,9
	4	MED	1080	6,78	583	19,3	6,11	526	16,2	5,44	468	13,4	4,78	411	10,8	4,11	354	8,4	3,45	297	6,2
	3		955	6,26	538	16,7	5,65	486	14,1	5,03	433	11,6	4,41	380	9,3	3,80	327	7,3	3,19	274	5,4
	2		815	5,65	486	13,9	5,10	438	11,7	4,55	391	9,7	3,99	343	7,8	3,43	295	6,1	2,88	248	4,5
	1	MIN	655	4,89	420	10,7	4,41	379	9,0	3,93	338	7,5	3,45	297	6,0	2,97	256	4,7	2,50	215	3,5
CRSL 53+1	5	MAX	1375	8,18	703	24,2	7,37	634	20,4	6,59	567	17,0	5,79	498	13,7	4,99	429	10,6	4,19	361	7,9
	4	MED	1030	6,79	584	17,4	6,13	528	14,7	5,48	471	12,2	4,81	413	9,8	4,15	357	7,6	3,49	300	5,7
	3		895	6,19	532	14,7	5,59	481	12,4	4,99	429	10,3	4,39	377	8,3	3,79	326	6,5	3,19	274	4,8
	2		760	5,55	477	12,1	5,02	432	10,2	4,48	385	8,5	3,94	339	6,8	3,40	293	5,3	2,86	246	4,0
	1	MIN	595	4,71	405	9,0	4,25	366	7,6	3,80	327	6,3	3,34	287	5,1	2,89	249	4,0	2,43	209	3,0
CRSL 63+1	5	MAX	1635	9,75	839	37,2	8,82	759	31,5	7,87	677	26,1	6,93	596	21,1	5,99	515	16,5	5,04	434	12,3
	4	MED	1425	8,94	769	31,8	8,08	695	26,9	7,21	620	22,3	6,35	547	18,1	5,49	472	14,1	4,62	398	10,5
	3		1210	8,04	691	26,3	7,27	625	22,3	6,49	558	18,5	5,72	492	14,9	4,94	425	11,7	4,17	359	8,8
	2		1015	7,95	684	25,8	7,20	619	21,8	6,42	552	18,1	5,66	487	14,7	4,89	420	11,5	4,12	354	8,6
	1	MIN	720	5,68	489	14,1	5,13	441	11,9	4,60	395	9,9	4,05	348	8,0	3,50	301	6,3	2,95	254	4,7
CRSL 73+1	5		2100	11,45	985	49,7	10,35	890	42,0	9,23	794	34,8	8,12	699	28,1	7,03	604	22,0	5,91	508	16,4
	4	MAX	1810	10,41	895	41,8	9,41	809	35,4	8,40	723	29,4	7,40	637	23,8	6,39	550	18,6	5,38	463	13,9
	3	MED	1490	9,20	791	33,5	8,31	715	28,3	7,42	638	23,5	6,53	562	19,0	5,65	486	14,9	4,76	409	11,1
	2		1190	7,95	684	25,8	7,20	619	21,8	6,42	552	18,1	5,66	487	14,7	4,89	420	11,5	4,12	354	8,6
	1	MIN	970	6,95	598	20,2	6,28	540	17,1	5,62	483	14,2	4,94	425	11,5	4,28	368	9,0	3,61	310	6,8

WT: Water temperature
Qv: Air flow
Ph: Heating emission
Qw: Water flow rate
Dp(h): Dp Heating

2 row heating additional coil unit

3 row version only

Entering air temperature: 20 °C - Available pressure: 0 Pa

Model	Speed		WT: 65 / 55 °C				WT: 60 / 50 °C			WT: 55 / 45 °C			WT: 50 / 40 °C			WT: 45 / 40 °C			WT: 45 / 35 °C		
			Qv m ³ /h	Ph kW	Qw l/h	Dp(h) kPa	Ph kW	Qw l/h	Dp(h) kPa	Ph kW	Qw l/h	Dp(h) kPa	Ph kW	Qw l/h	Dp(h) kPa	Ph kW	Qw l/h	Dp(h) kPa	Ph kW	Qw l/h	Dp(h) kPa
CRSL 13+2	5	MAX	535	4,06	349	9,8	3,50	301	7,6	2,94	253	5,7	2,39	205	3,9	2,27	391	12,7	1,83	157	2,5
	4	MED	490	3,81	328	8,7	3,29	283	6,8	2,77	238	5,1	2,25	193	3,5	2,14	368	11,4	1,72	148	2,2
	3		445	3,56	306	7,7	3,07	264	6,0	2,59	222	4,5	2,10	180	3,1	2,00	343	10,1	1,61	138	2,0
	2		400	3,30	283	6,7	2,85	245	5,2	2,39	206	3,9	1,95	167	2,7	1,85	318	8,8	1,49	128	1,7
	1	MIN	340	2,92	251	5,4	2,53	217	4,2	2,12	183	3,1	1,73	149	2,2	1,64	282	7,1	1,33	114	1,4
CRSL 23+2	5	MAX	860	6,35	546	27,8	5,50	473	21,8	4,64	399	16,4	3,78	325	11,5	3,57	614	36,5	2,92	251	7,4
	4	MED	780	5,94	511	24,7	5,14	442	19,3	4,34	373	14,5	3,54	304	10,2	3,33	573	32,3	2,74	236	6,6
	3		660	5,27	453	19,9	4,57	393	15,6	3,86	332	11,7	3,14	270	8,3	2,96	509	26,1	2,44	210	5,3
	2		600	4,93	424	17,6	4,27	367	13,8	3,60	310	10,4	2,94	253	7,3	2,77	476	23,1	2,27	196	4,7
	1	MIN	515	4,40	379	14,4	3,81	328	11,3	3,22	277	8,5	2,63	226	6,0	2,47	425	18,9	2,04	176	3,9
CRSL 33+2	5	MAX	1115	8,30	714	47,6	7,20	619	37,5	6,10	524	28,3	4,98	429	20,0	4,67	802	62,5	3,87	333	12,9
	4	MED	960	7,49	644	39,5	6,48	557	31,0	5,49	472	23,4	4,49	386	16,6	4,20	722	51,7	3,49	300	10,7
	3		750	6,26	538	28,6	5,43	467	22,6	4,60	396	17,0	3,77	324	12,1	3,52	605	37,6	2,93	252	7,8
	2		620	5,44	468	22,2	4,72	406	17,5	4,00	344	13,3	3,27	281	9,4	3,06	526	29,2	2,55	220	6,1
	1	MIN	500	4,62	397	16,6	4,01	345	13,1	3,40	292	9,9	2,79	240	7,0	2,60	447	21,8	2,17	187	4,6
CRSL 43+2	5	MAX	1340	9,42	810	59,7	8,16	702	47,0	6,89	593	35,3	5,65	486	25,1	5,29	909	78,3	4,38	376	16,1
	4	MED	1080	8,12	698	45,7	7,03	605	35,9	5,95	512	27,1	4,87	419	19,2	4,56	785	60,1	3,78	325	12,4
	3		955	7,45	640	39,1	6,46	555	30,8	5,46	470	23,2	4,48	385	16,5	4,18	720	51,4	3,48	299	10,7
	2		815	6,64	571	31,9	5,77	496	25,1	4,89	420	19,0	4,00	344	13,5	3,74	643	41,9	3,11	267	8,7
	1	MIN	655	5,67	487	23,9	4,92	423	18,9	4,17	358	14,3	3,41	293	10,1	3,18	547	31,4	2,65	228	6,6

WT: Water temperature
Qv: Air flow
Ph: Heating emission
Qw: Water flow rate
Dp(h): Dp Heating

CORRECTION FACTOR TABLES

Air flow depending on speed and requested available pressure

Air flow (m³/h)

Model	Speed	Available pressure (Pa)								
		0	10	20	30	40	50	60	70	80
1	5	535	505	475	440	398	350	300	250	200
	4	490	460	425	387	340	293	243	194	142
	3	445	413	378	334	287	240	192	145	-
	2	400	362	317	267	218	172	127	-	-
	1	340	295	240	188	143	97	-	-	-
2	5	860	830	795	758	715	670	615	553	485
	4	780	750	713	675	630	580	525	465	400
	3	660	625	587	545	500	455	402	345	280
	2	600	558	515	470	423	374	323	270	-
	1	515	462	412	363	315	265	215	-	-
3	5	1115	1075	1030	980	925	868	803	735	660
	4	960	922	875	825	775	722	664	600	530
	3	750	700	650	602	555	505	455	400	340
	2	620	545	482	435	390	341	295	245	-
	1	500	404	342	288	240	192	-	-	-
4	5	1340	1300	1260	1214	1160	1100	1030	950	860
	4	1080	1050	1018	980	938	880	820	750	665
	3	950	920	885	850	805	760	705	640	575
	2	805	780	745	710	670	620	578	524	470
	1	655	620	585	550	515	480	440	397	345
5	5	1375	1335	1290	1240	1185	1115	1062	995	907
	4	1025	995	958	920	878	814	776	710	640
	3	895	855	820	780	735	690	640	590	520
	2	760	710	670	630	590	550	505	460	-
	1	595	530	475	423	380	330	-	-	-
6	5	1635	1575	1518	1450	1385	1312	1240	1155	1065
	4	1425	1376	1312	1250	1185	1120	1045	960	880
	3	1210	1160	1100	1042	980	920	850	775	690
	2	1015	946	882	823	760	700	640	570	495
	1	720	625	535	455	382	323	-	-	-
7	5	2100	2040	1980	1910	1840	1760	1680	1585	1480
	4	1810	1760	1707	1650	1585	1520	1440	1355	1260
	3	1490	1458	1420	1370	1322	1272	1217	1140	1050
	2	1190	1165	1140	1110	1070	1030	980	930	850
	1	970	945	922	897	862	830	790	742	680

Power absorption depending on air flow and available pressure

Power absorbed (Watt)

Model	Speed	Available pressure (Pa)								
		0	10	20	30	40	50	60	70	80
1	5	55,0	54,0	53,5	52,7	52,0	51,0	50,0	48,7	48,0
	4	47,5	47,0	46,5	45,7	44,8	44,0	42,9	41,8	40,6
	3	41,0	40,5	40,2	39,5	38,7	38,0	37,0	36,2	-
	2	34,5	34,5	33,5	33,0	32,2	31,5	30,7	-	-
	1	27,5	27,5	27,0	26,2	25,5	24,8	-	-	-
2	5	111,0	108,0	105,0	103,0	100,0	96,5	93,0	89,0	85,0
	4	98,0	96,0	94,0	91,5	89,0	86,0	82,5	78,5	75,0
	3	82,0	80,0	78,5	76,0	74,0	71,0	68,0	65,0	61,0
	2	73,0	72,5	71,0	68,5	66,0	64,0	61,0	58,0	-
	1	62,0	61,0	60,0	58,0	56,0	53,0	51,0	-	-
3	5	127,0	123,0	120,0	117,5	115,0	111,5	108,0	104,5	101,0
	4	106,0	104,0	102,0	99,0	96,0	93,0	91,0	87,0	84,0
	3	80,0	79,0	77,0	75,0	73,0	71,0	69,0	66,0	63,0
	2	64,0	63,0	61,5	60,0	58,5	56,5	55,0	53,0	-
	1	50,0	50,0	49,0	47,5	46,0	45,0	-	-	-
4	5	175,0	171,0	167,0	163,0	159,0	153,0	148,0	141,0	135,0
	4	143,0	138,0	134,0	130,0	125,0	120,0	114,0	108,0	101,0
	3	126,0	123,0	119,0	115,0	111,0	106,0	101,0	95,0	89,0
	2	109,0	106,0	103,0	99,0	95,0	91,0	87,0	83,0	79,0
	1	95,0	91,0	89,0	86,0	83,0	81,0	77,0	73,0	69,0
5	5	174,0	170,0	166,0	161,0	156,0	150,0	146,0	140,0	134,0
	4	128,0	125,0	122,0	118,0	115,0	109,0	105,0	102,0	97,0
	3	111,0	108,0	105,0	102,0	98,0	95,0	91,0	88,0	84,0
	2	94,0	91,0	88,0	86,0	84,0	81,0	78,0	75,0	-
	1	70,0	69,0	67,0	65,0	63,0	60,0	-	-	-
6	5	166,0	163,0	160,0	156,0	153,0	148,0	144,0	139,0	134,0
	4	144,0	141,0	138,0	135,0	131,0	128,0	123,0	118,0	114,0
	3	122,0	120,0	117,0	115,0	112,0	109,0	106,0	102,0	97,0
	2	100,0	99,0	98,0	96,0	94,0	91,0	88,0	84,0	80,0
	1	68,0	68,0	67,0	65,0	63,0	61,0	-	-	-
7	5	245,0	240,0	236,0	231,0	226,0	219,0	212,0	205,0	196,0
	4	228,0	222,0	218,0	211,0	205,0	198,0	189,0	181,0	172,0
	3	213,0	207,0	202,0	195,0	188,0	181,0	172,0	164,0	153,0
	2	186,0	180,0	176,0	171,0	164,0	158,0	150,0	143,0	133,0
	1	163,0	158,0	154,0	149,0	144,0	138,0	133,0	126,0	117,0

Correction factors for Total cooling emission

Values in %

Model	Speed	Available pressure (Pa)								
		0	10	20	30	40	50	60	70	80
1	5	1,00	0,97	0,94	0,90	0,85	0,79	0,71	0,63	0,54
	4	1,00	0,97	0,93	0,88	0,81	0,74	0,66	0,56	0,46
	3	1,00	0,96	0,92	0,85	0,78	0,69	0,60	0,50	-
	2	1,00	0,95	0,88	0,79	0,70	0,60	0,49	-	-
	1	1,00	0,93	0,82	0,70	0,59	0,45	-	-	-
2	5	1,00	0,98	0,96	0,94	0,91	0,87	0,83	0,78	0,71
	4	1,00	0,98	0,95	0,93	0,89	0,85	0,80	0,74	0,67
	3	1,00	0,97	0,94	0,90	0,86	0,81	0,75	0,68	0,59
	2	1,00	0,96	0,92	0,88	0,82	0,76	0,69	0,62	-
	1	1,00	0,94	0,89	0,82	0,75	0,67	0,59	-	-
3	5	1,00	0,98	0,96	0,93	0,90	0,87	0,83	0,79	0,74
	4	1,00	0,98	0,95	0,92	0,89	0,85	0,81	0,76	0,70
	3	1,00	0,96	0,93	0,89	0,85	0,80	0,75	0,69	0,62
	2	1,00	0,93	0,87	0,82	0,77	0,70	0,64	0,56	-
	1	1,00	0,89	0,81	0,72	0,64	0,55	-	-	-
4	5	1,00	0,98	0,97	0,95	0,93	0,90	0,87	0,82	0,78
	4	1,00	0,98	0,97	0,95	0,93	0,90	0,86	0,81	0,76
	3	1,00	0,98	0,96	0,94	0,92	0,89	0,85	0,80	0,75
	2	1,00	0,98	0,96	0,94	0,91	0,87	0,83	0,78	0,73
	1	1,00	0,97	0,94	0,91	0,88	0,84	0,80	0,75	0,68
5	5	1,00	0,98	0,97	0,95	0,92	0,89	0,87	0,84	0,79
	4	1,00	0,98	0,96	0,94	0,92	0,88	0,86	0,81	0,76
	3	1,00	0,98	0,95	0,93	0,90	0,87	0,83	0,79	0,73
	2	1,00	0,96	0,94	0,90	0,87	0,84	0,79	0,75	-
	1	1,00	0,94	0,89	0,83	0,77	0,71	-	-	-
6	5	1,00	0,98	0,96	0,94	0,92	0,89	0,86	0,82	0,78
	4	1,00	0,98	0,96	0,93	0,91	0,88	0,84	0,80	0,76
	3	1,00	0,98	0,95	0,92	0,89	0,86	0,82	0,77	0,72
	2	1,00	0,96	0,93	0,89	0,85	0,81	0,77	0,71	0,65
	1	1,00	0,93	0,85	0,77	0,69	0,61	-	-	-
7	5	1,00	0,98	0,97	0,95	0,93	0,91	0,89	0,86	0,82
	4	1,00	0,98	0,97	0,95	0,93	0,91	0,88	0,85	0,82
	3	1,00	0,99	0,97	0,96	0,94	0,92	0,90	0,86	0,82
	2	1,00	0,99	0,98	0,96	0,95	0,93	0,90	0,87	0,83
	1	1,00	0,99	0,97	0,96	0,94	0,92	0,90	0,86	0,82

Correction factors for Sensible cooling emission and Heating emission

Values in %

Model	Speed	Available pressure (Pa)								
		0	10	20	30	40	50	60	70	80
1	5	1,00	0,96	0,92	0,87	0,81	0,73	0,65	0,57	0,48
	4	1,00	0,96	0,90	0,85	0,77	0,69	0,59	0,50	0,39
	3	1,00	0,95	0,89	0,81	0,73	0,63	0,53	0,43	-
	2	1,00	0,93	0,85	0,75	0,64	0,53	0,42	-	-
	1	1,00	0,90	0,78	0,65	0,52	0,39	-	-	-
2	5	1,00	0,97	0,95	0,91	0,88	0,84	0,79	0,72	0,66
	4	1,00	0,97	0,94	0,90	0,86	0,81	0,75	0,68	0,61
	3	1,00	0,96	0,92	0,87	0,82	0,76	0,70	0,62	0,53
	2	1,00	0,95	0,90	0,84	0,78	0,71	0,63	0,55	-
	1	1,00	0,93	0,85	0,78	0,70	0,61	0,52	-	-
3	5	1,00	0,97	0,95	0,91	0,88	0,84	0,79	0,74	0,68
	4	1,00	0,97	0,94	0,90	0,86	0,82	0,77	0,71	0,65
	3	1,00	0,95	0,90	0,86	0,81	0,75	0,69	0,63	0,55
	2	1,00	0,91	0,84	0,77	0,71	0,64	0,57	0,50	-
	1	1,00	0,86	0,76	0,67	0,58	0,49	-	-	-
4	5	1,00	0,98	0,96	0,93	0,90	0,87	0,83	0,78	0,72
	4	1,00	0,98	0,96	0,93	0,91	0,86	0,82	0,77	0,70
	3	1,00	0,98	0,95	0,92	0,89	0,85	0,81	0,75	0,69
	2	1,00	0,98	0,95	0,92	0,88	0,83	0,79	0,73	0,67
	1	1,00	0,96	0,92	0,88	0,84	0,80	0,75	0,69	0,62
5	5	1,00	0,98	0,96	0,93	0,90	0,86	0,83	0,79	0,74
	4	1,00	0,98	0,95	0,93	0,90	0,85	0,82	0,77	0,71
	3	1,00	0,97	0,94	0,91	0,87	0,83	0,79	0,74	0,67
	2	1,00	0,95	0,91	0,88	0,83	0,79	0,74	0,69	-
	1	1,00	0,92	0,85	0,78	0,72	0,65	-	-	-
6	5	1,00	0,97	0,95	0,92	0,89	0,86	0,82	0,78	0,73
	4	1,00	0,97	0,94	0,91	0,88	0,84	0,80	0,75	0,70
	3	1,00	0,97	0,93	0,90	0,86	0,82	0,77	0,72	0,66
	2	1,00	0,95	0,91	0,86	0,81	0,76	0,71	0,65	0,59
	1	1,00	0,90	0,81	0,72	0,63	0,55	-	-	-
7	5	1,00	0,98	0,96	0,94	0,91	0,88	0,85	0,82	0,78
	4	1,00	0,98	0,96	0,94	0,91	0,88	0,85	0,81	0,77
	3	1,00	0,98	0,97	0,94	0,92	0,89	0,87	0,83	0,78
	2	1,00	0,98	0,97	0,95	0,93	0,90	0,87	0,84	0,78
	1	1,00	0,98	0,96	0,95	0,92	0,90	0,86	0,83	0,77

WATER SIDE PRESSURE DROPS

Main coil

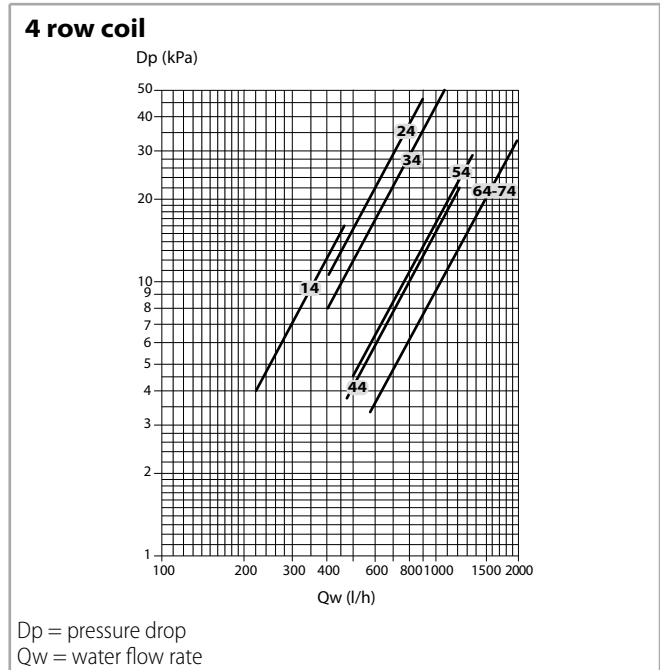
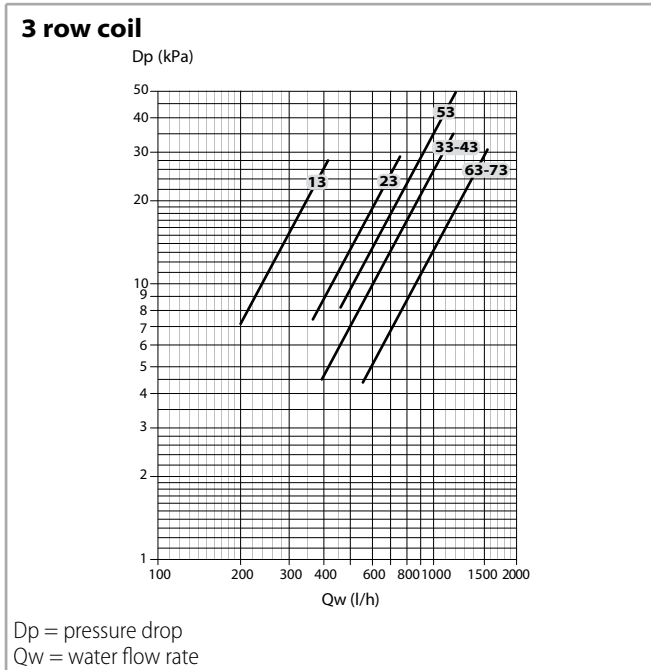

Pressure drop for mean water temperature of 10 °C, for different temperatures multiply the pressure drop figure by the K correction factors in the table.

	Mean water temperature (°C)						
	20	30	40	50	60	70	80
K correction factor	0,94	0,90	0,86	0,82	0,78	0,74	0,70

Additional coil

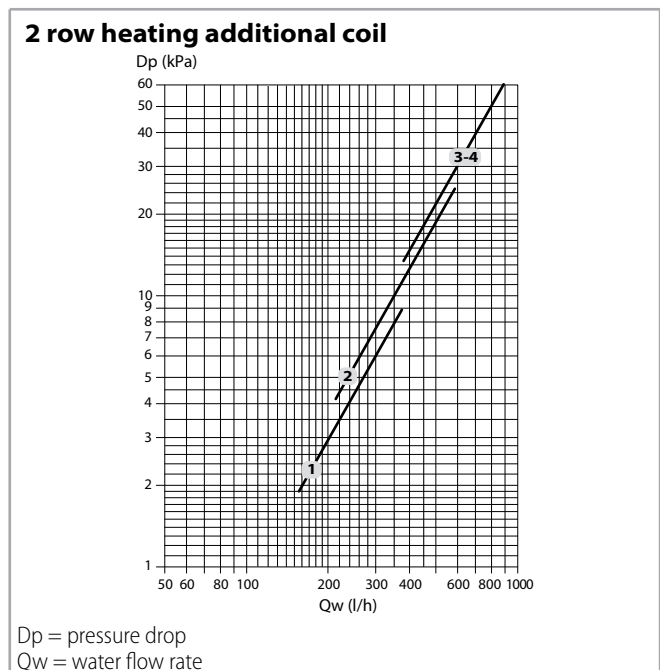
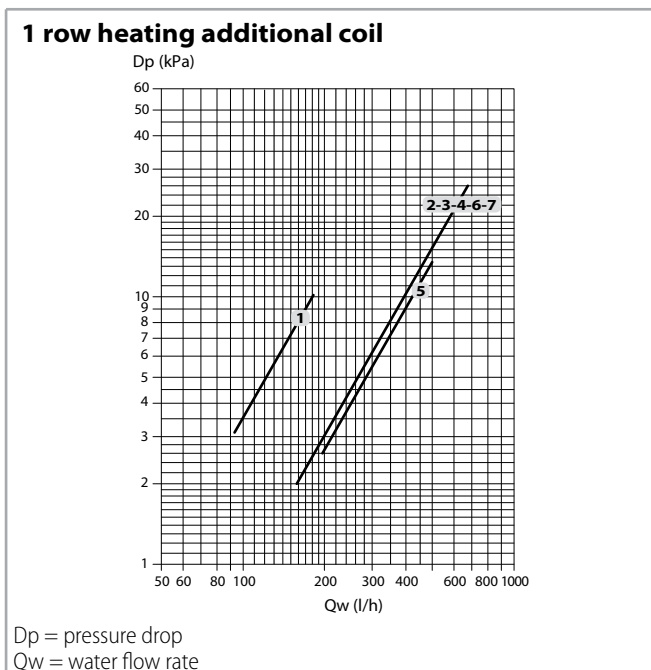

Pressure drop for mean water temperature of 60 °C, for different temperatures multiply the pressure drop figure by the K correction factors in the table.

	Mean water temperature (°C)			
	40	50	70	80
K correction factor	1,12	1,06	0,94	0,88

OPERATING LIMITS

Description		UoM	Value
Water flow	Max. water pressure drop	bars	10
	MIN. entering water temperature	°C	+5
	MAX. entering water temperature	°C	+85
Power supply	Single-phase rated operating voltage	V/Hz	230/50

Electric heater operation limits

Description		UoM	Value
Ambient air	Maximum temperature ⁽¹⁾	°C	+25
Power supply	Single-phase rated operating voltage	Vac/Ph/Hz	230/1/50

⁽¹⁾ with heating coil

Coils water flow limits

3 row coil

Model		CRSL 13	CRSL 23	CRSL 33	CRSL 43	CRSL 53	CRSL 63	CRSL 73
Water flow rate Min.	l/h	100	150	200	250	300	300	300
Water flow rate Max.	l/h	750	1000	2000	2500	3000	3000	3000

4 row coil

Model		CRSL 14	CRSL 24	CRSL 34	CRSL 44	CRSL 54	CRSL 64	CRSL 74
Water flow rate Min.	l/h	150	300	350	400	400	400	400
Water flow rate Max.	l/h	1000	1500	2250	2750	3300	3300	3300

1 row heating additional coil

Model		CRSL 13+1	CRSL 23+1	CRSL 33+1	CRSL 43+1	CRSL 53+1	CRSL 63+1	CRSL 73+1
Water flow rate Min.	l/h	50	100	100	100	100	100	100
Water flow rate Max.	l/h	350	500	750	750	750	750	750

Model		CRSL 14+1	CRSL 24+1	CRSL 34+1	CRSL 44+1	CRSL 54+1	CRSL 64+1	CRSL 74+1
Water flow rate Min.	l/h	50	100	100	100	100	100	100
Water flow rate Max.	l/h	350	500	750	750	750	750	750

2 row heating additional coil

Model		CRSL 13+2	CRSL 23+2	CRSL 33+2	CRSL 43+2
Water flow rate Min.	l/h	100	100	100	100
Water flow rate Max.	l/h	350	500	750	750

Motor electrical data - max. absorption

Model		CRSL 1	CRSL 2	CRSL 3	CRSL 4	CRSL 5	CRSL 6	CRSL 7
Motor absorption	W	60	115	132	185	175	260	260
Current absorbed	A	0,3	0,5	0,6	0,9	0,8	1,2	1,2

DIMENSION, WEIGHT AND WATER CONTENT

Dimensions

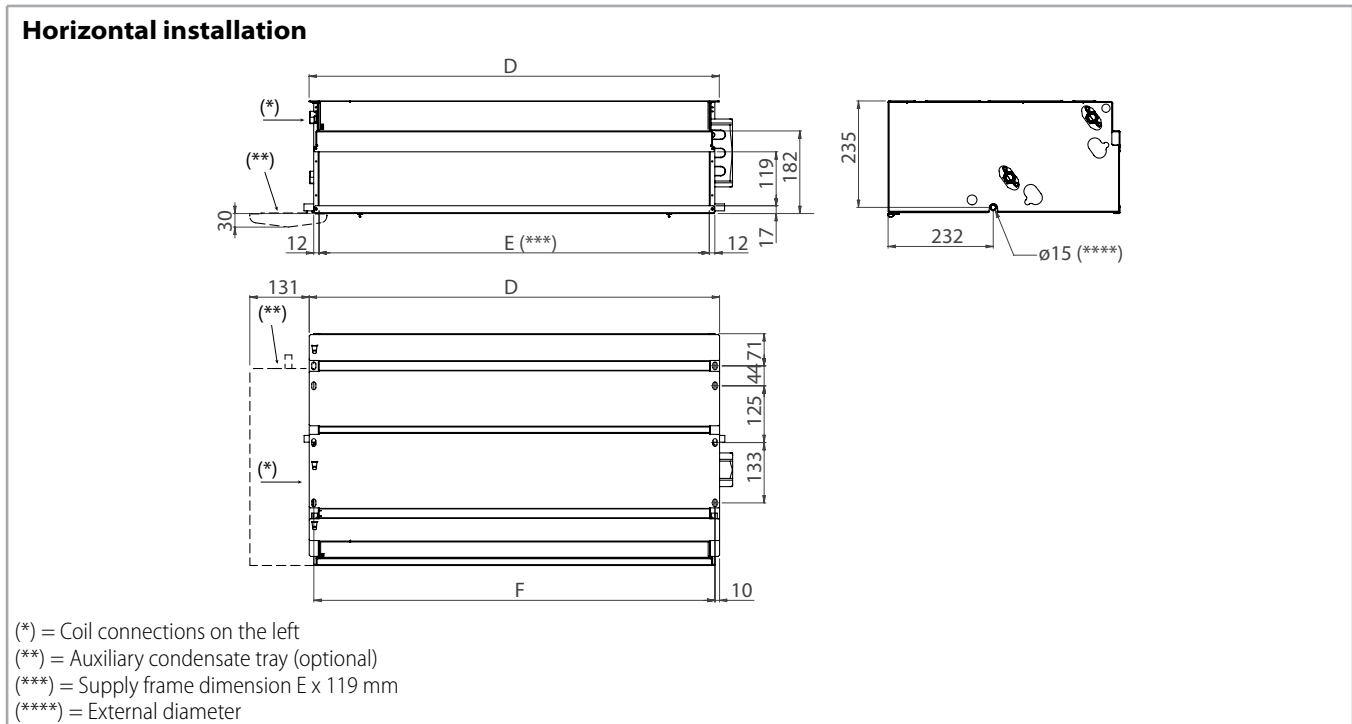
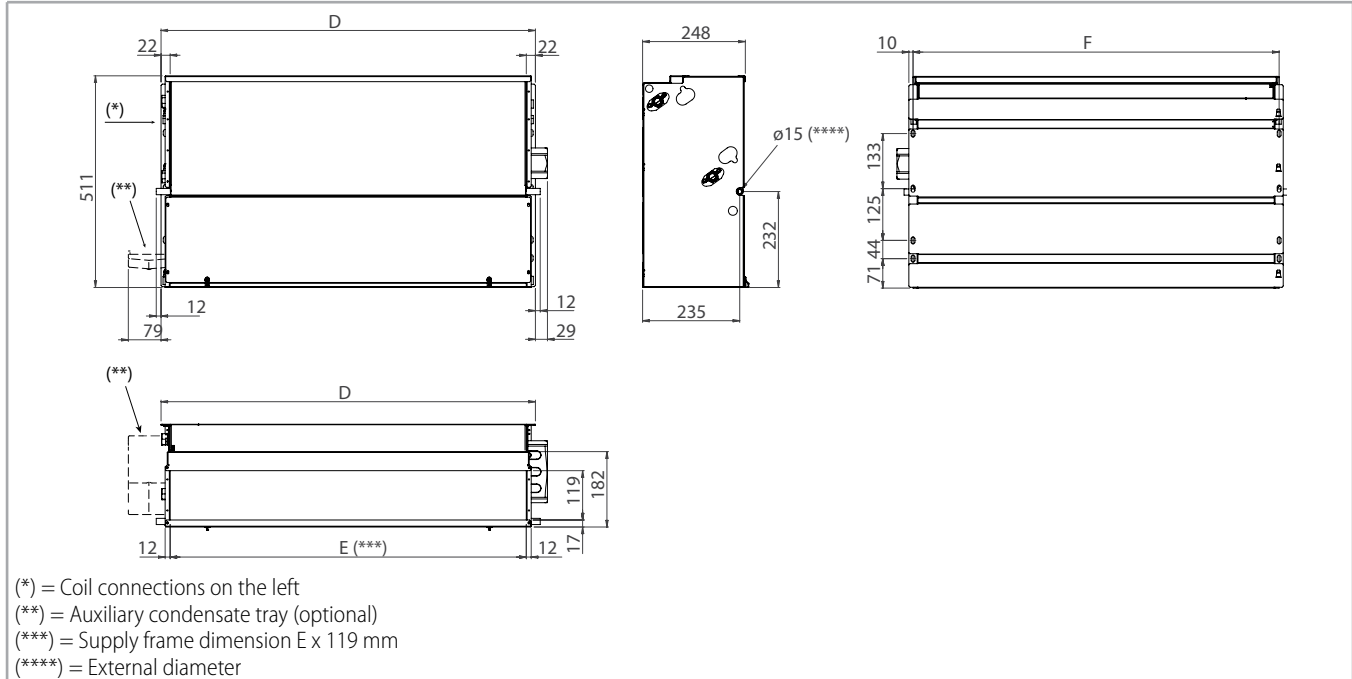

Model		CRSL 1	CRSL 2	CRSL 3	CRSL 4	CRSL 5	CRSL 6	CRSL 7
D	mm	689	904	1119	1334	1549		
E	mm	645	860	1075	1290	1505		
F	mm	669	884	1099	1314	1529		

Coil connections

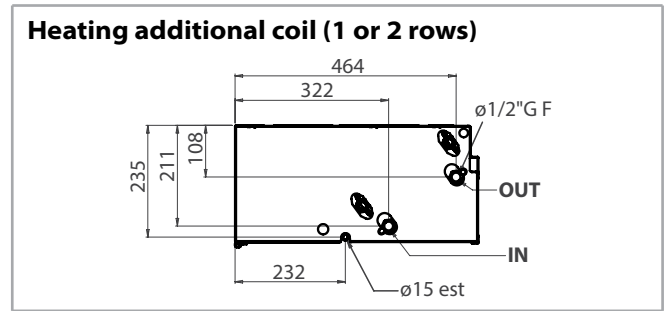
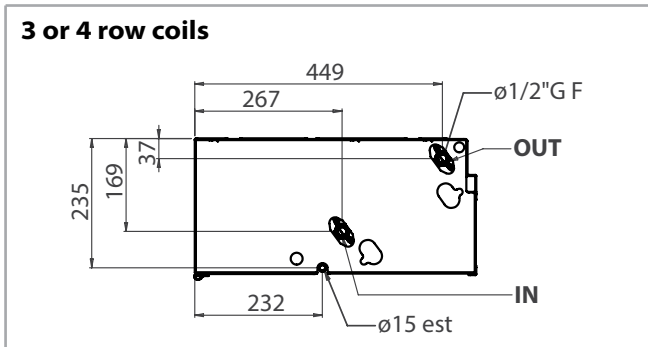

Packed unit

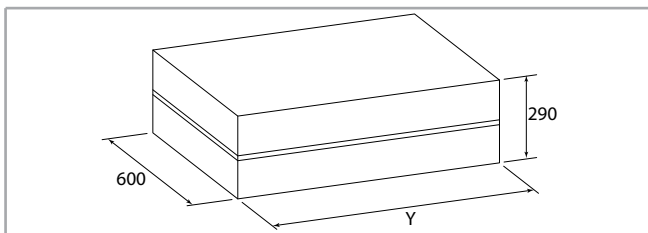

Model		CRSL 1	CRSL 2	CRSL 3	CRSL 4	CRSL 5	CRSL 6	CRSL 7
Y	mm	820	1035	1250	1580	1790		

Weight

Weights with packaging

Model		CRSL 1	CRSL 2	CRSL 3	CRSL 4	CRSL 5	CRSL 6	CRSL 7
3 rows	kg	19,5	26,4	29,5	30,9	42,4	52,2	52,4
3+1 rows	kg	20,7	27,9	31,3	32,7	44,3	54,5	54,7
3+2 rows	kg	21,4	28,8	32,4	33,8	-	-	-
4 rows	kg	20,5	27,7	30,9	32,0	43,8	53,9	54,1
4+1 rows	kg	21,7	29,2	32,7	33,8	45,7	56,2	56,4

Weights without packaging

Model		CRSL 1	CRSL 2	CRSL 3	CRSL 4	CRSL 5	CRSL 6	CRSL 7
3 rows	kg	18,5	25,4	26,5	27,9	38,4	47,2	47,4
3+1 rows	kg	19,7	26,9	28,3	29,7	40,3	49,5	49,7
3+2 rows	kg	20,4	27,8	29,4	30,8	-	-	-
4 rows	kg	19,5	26,7	27,9	29,0	39,8	48,9	49,1
4+1 rows	kg	20,7	28,2	29,7	30,8	41,7	51,2	51,4

Water content

Model		CRSL 1	CRSL 2	CRSL 3	CRSL 4	CRSL 5	CRSL 6	CRSL 7
3 rows	l	0,9	1,6	1,9	1,9	2,6	3,2	3,2
4 rows	l	1,3	2,2	2,8	2,8	3,4	4,2	4,2
+1 row	l	0,3	0,5	0,6	0,6	0,8	0,9	0,9
+2 rows	l	0,6	1,0	1,2	1,2	-	-	-

WALL ELECTRONIC CONTROLS

All the Carisma CRSL units can be supplied with a wide control range that allows to control a single unit or several units (through the use of Dip-Switches or the use of power units).

The options range from the basic 3 speed control WM-3V, to the highly sophisticated WM-T, WM-TQR and

T2T electronic room thermostats, that regulate the room temperature and are suitable when the user wants to set the fan speed.

The most evolved WM-AU, T-MB and WM-503 versions allow both the manual and the automatic speed switch.

Note: all the controls are described in detail in the "Fan Coil Control Range literature".

Controls

WM-3V control



230V 50Hz

WM-T control



230V 50-60Hz

WM-TQR control



230V 50-60Hz

WM-AU control (*)



230V 50-60Hz

T-MB control (*)



230V 50-60Hz

WM-503 control ()**



230V 50Hz

T2T control



230V 50-60Hz

(*) To be used with UPM-AU or UP-AU only

() To be used with UP-503 only**

MAIN COMPONENTS

Range includes 4 air flow rates (from 375 to 2460 m³/h), each equipped with 3 or 4 row coil and with the possibility to add a 1 or 2 row coil for 4 pipe systems.

It is the most comprehensive range, perfect to meet all air-conditioning requirements of work environments like offices, shops, restaurants and hotel rooms featuring ducted installations with available pressure up to 80 Pa.

Compliant with Regulation (EU) No. 327/2011.

Casing

Made from 1 mm galvanized steel insulated with 3 mm polyolefin (PO) foam (class M1).

Fan assembly

The fans have aluminium or plastic blades directly keyed on the motor with double aspiration and they are dynamically and statically balanced during manufacture in order to have an extremely quiet operation.

Electric motor

Three phase permanent magnet brushless electronic motor that is controlled with reconstructed current according to a BLAC sinusoidal wave.

The inverter board that controls the motor operation is powered by 230 Volt, single-phase and, with a switching system, it generates a three-phase frequency modulated, wave form power supply.

The electric power supply required for the machine is therefore single-phase with voltage of 230 V and frequency of 50-60 Hz.

Coil

It is manufactured from drawn copper tube and the aluminium fins are mechanically bonded onto the tube by an expansion process. The main coil and additional coil are equipped with two Ø 1/2" BSP female gas connections.

The connections are equipped with Ø 1/8" BSP air vent and drain.

The heat exchanger is not suitable for use in corrosive atmosphere or in environments where aluminium may be subject to corrosion.

The connections are on the left hand side looking from the air outlet of the unit (see picture).

On request or on site the connections can be moved to the other side.

Condensate collection tray

Made of plastic (ABS UL94 HB) for sizes 1÷3 and painted steel for the size 4 with a L-shaped fitted on the inner casing; the tray is insulated with 3 mm polyolefin (PO) foam (class M1). The outside diameter of the condensate discharge pipe is 15 mm.

Filter

Polypropylene cellular fabric regenerating filter.

The filter frame of galvanized steel is inserted into special plastic sliding guides fastened to the internal structure for easy insertion and removal of the filter.

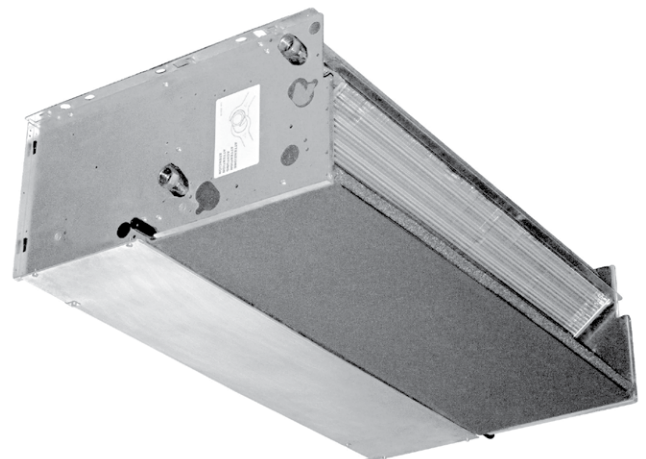

EUROVENT CERTIFICATIONS

3 row coil unit - 2 pipe models

The following standard rating conditions are used:

COOLING

Entering air temperature: + 27 °C d.b. + 19 °C w.b.
Water temperature: +7 °C E.W.T. +12 °C L.W.T.

HEATING

Entering air temperature: + 20 °C
Water temperature: +45 °C E.W.T. +40 °C L.W.T.

MODEL	Speed	CRSL-ECM 13			CRSL-ECM 23			CRSL-ECM 43			CRSL-ECM 73		
		4 MIN	6,3 MED	8 MAX	4 MIN	6,5 MED	8,5 MAX	3,5 MIN	7 MED	9 MAX	2,5 MIN	5 MED	8 MAX
Air flow (E)	m ³ /h	240	305	360	430	540	630	595	835	960	900	1175	1410
Available pressure (E)	Pa	32	50	68	34	50	70	24	50	66	30	50	72
Cooling total emission (E)	kW	1,64	1,97	2,23	2,72	3,21	3,55	3,84	4,94	5,43	5,66	6,81	7,67
Cooling sensible emission (E)	kW	1,17	1,42	1,63	1,99	2,38	2,68	2,83	3,77	4,21	4,15	5,11	5,86
Heating emission (E)	kW	1,65	2,05	2,37	2,88	3,51	4,00	4,07	5,56	6,27	5,69	7,09	8,24
Dp Cooling (E)	kPa	13,3	18,7	23,5	11,5	15,6	18,9	11,8	18,9	22,5	12,1	17,1	21,4
Dp Heating (E)	kPa	11,6	17,0	22,1	10,2	14,6	18,5	10,6	18,6	23,0	9,8	14,6	19,1
Motor power input (E)	W	18	29	39	27	46	67	30	67	98	52	100	155
Sound power outlet (Lw) (E)	dB(A)	38	44	48	38	47	49	44	52	55	47	54	57
Sound power inlet + radiated (Lw) (E)	dB(A)	45	51	55	45	55	58	51	59	62	54	61	64
Sound pressure level outlet (Lp) ⁽¹⁾	dB(A)	29	35	39	29	38	40	35	43	46	38	45	48
Sound pressure level inlet + radiated (Lp) ⁽¹⁾	dB(A)	36	42	46	36	46	49	42	50	53	45	52	55
Plenum code (E)		9069191	9069191	9069191	9069222	9069222	9069222	9066368	9066368	9066368	9069196	9069196	9069196

(E) Eurovent certified performance.

(1) The sound pressure levels are 9 dB (A) lower than the sound power levels, apply to the reverberant field of a 100 m³ room and a reverberation time of 0.5 sec.

4 row coil unit - 2 pipe models

The following standard rating conditions are used:

COOLING

Entering air temperature: + 27 °C d.b. + 19 °C w.b.
Water temperature: +7 °C E.W.T. +12 °C L.W.T.

HEATING

Entering air temperature: + 20 °C
Water temperature: +45 °C E.W.T. +40 °C L.W.T.

MODEL	Speed	CRSL-ECM 14			CRSL-ECM 24			CRSL-ECM 44			CRSL-ECM 74		
		4 MIN	6,3 MED	8 MAX	4 MIN	6,5 MED	8,5 MAX	3,5 MIN	7 MED	9 MAX	2,5 MIN	5 MED	8 MAX
Air flow (E)	m ³ /h	240	305	360	430	540	630	595	835	960	900	1175	1410
Available pressure (E)	Pa	32	50	68	34	50	70	24	50	66	30	50	72
Cooling total emission (E)	kW	1,77	2,17	2,48	3,14	3,79	4,25	4,09	5,34	5,91	6,12	7,46	8,47
Cooling sensible emission (E)	kW	1,25	1,54	1,78	2,20	2,68	3,04	2,95	3,97	4,45	4,40	5,48	6,33
Heating emission (E)	kW	1,73	2,17	2,52	3,08	3,80	4,37	4,19	5,77	6,55	6,26	7,96	9,35
Dp Cooling (E)	kPa	7,2	10,3	13,2	17,5	24,7	30,6	7,7	12,6	15,2	9,9	14,3	18,1
Dp Heating (E)	kPa	6,7	9,9	13,1	14,1	20,6	26,6	6,5	11,5	14,5	8,9	13,8	18,4
Motor power input (E)	W	18	29	39	27	46	67	30	67	98	52	100	155
Sound power outlet (Lw) (E)	dB(A)	38	44	48	38	47	49	44	52	55	47	54	57
Sound power inlet + radiated (Lw) (E)	dB(A)	45	51	55	45	55	58	51	59	62	54	61	64
Sound pressure level outlet (Lp) ⁽¹⁾	dB(A)	29	35	39	29	38	40	35	43	46	38	45	48
Sound pressure level inlet + radiated (Lp) ⁽¹⁾	dB(A)	36	42	46	36	46	49	42	50	53	45	52	55
Plenum code (E)		9069191	9069191	9069191	9069222	9069222	9069222	9066368	9066368	9066368	9069196	9069196	9069196

(E) Eurovent certified performance.

(1) The sound pressure levels are 9 dB (A) lower than the sound power levels, apply to the reverberant field of a 100 m³ room and a reverberation time of 0.5 sec.

3+1 row coil unit - 4 pipe models

The following standard rating conditions are used:

COOLING

Entering air temperature: + 27 °C d.b. + 19 °C w.b.
Water temperature: +7 °C E.W.T. +12 °C L.W.T.

HEATING

Entering air temperature: + 20 °C
Water temperature: +65 °C E.W.T. +55 °C L.W.T.

MODEL	Speed	CRSL-ECM 13+1			CRSL-ECM 23+1			CRSL-ECM 43+1			CRSL-ECM 73+1		
		4 MIN	6,3 MED	8 MAX	4 MIN	6,5 MED	8,5 MAX	3,5 MIN	7 MED	9 MAX	2,5 MIN	5 MED	8 MAX
Air flow (E)	m ³ /h	240	305	360	430	540	630	595	835	960	900	1175	1410
Available pressure (E)	Pa	32	50	68	34	50	70	24	50	66	30	50	72
Cooling total emission (E)	kW	1,64	1,97	2,23	2,72	3,21	3,55	3,84	4,88	5,35	5,66	6,81	7,67
Cooling sensible emission (E)	kW	1,17	1,42	1,63	1,98	2,38	2,67	2,83	3,71	4,13	4,15	5,11	5,86
Heating emission (E)	kW	1,46	1,72	1,92	2,36	2,74	3,03	3,09	3,87	4,22	4,70	5,60	6,31
Dp Cooling (E)	kPa	13,3	18,7	23,5	11,5	15,6	18,9	11,8	18,4	21,9	12,1	17,1	21,4
Dp Heating (E)	kPa	5,4	7,2	8,9	3,1	4,0	4,8	4,9	7,4	8,6	10,5	14,4	17,8
Motor power input (E)	W	18	29	39	27	46	67	30	67	98	52	100	155
Sound power outlet (Lw) (E)	dB(A)	38	44	48	38	47	49	44	52	55	47	54	57
Sound power inlet + radiated (Lw) (E)	dB(A)	45	51	55	45	55	58	51	59	62	54	61	64
Sound pressure level outlet (Lp) ⁽¹⁾	dB(A)	29	35	39	29	38	40	35	43	46	38	45	48
Sound pressure level inlet + radiated (Lp) ⁽¹⁾	dB(A)	36	42	46	36	46	49	42	50	53	45	52	55
Plenum code (E)		9069191	9069191	9069191	9069222	9069222	9069222	9066368	9066368	9066368	9069196	9069196	9069196

(E) Eurovent certified performance.

(1) The sound pressure levels are 9 dB (A) lower than the sound power levels, apply to the reverberant field of a 100 m³ room and a reverberation time of 0.5 sec.

MAIN PERFORMANCE AND TECHNICAL CHARACTERISTICS

3 row coil unit - 2 pipe models

The following standard rating conditions are used:

COOLING

Entering air temperature: + 27 °C d.b. + 19 °C w.b.
Water temperature: +7 °C E.W.T. +12 °C L.W.T.

HEATING

Entering air temperature: + 20 °C
Water temperature: +45 °C E.W.T. +40 °C L.W.T.

Available pressure: 0 Pa

MODEL	Speed	CRSL-ECM 13					CRSL-ECM 23					CRSL-ECM 43					CRSL-ECM 73				
		1	3	5	7,5	10	1	3	5	7,5	10	1	3	5	7,5	10	1	3	5	7,5	10
		MIN		MED		MAX	MIN		MED		MAX	MIN		MED		MAX	MIN		MED		MAX
Air flow	m ³ /h	330	440	560	650	650	550	710	880	1085	1235	615	830	1055	1315	1390	880	1240	1605	2110	2460
Cooling total emission	kW	2,11	2,59	3,04	3,39	3,34	3,27	3,89	4,46	5,15	5,44	3,95	4,89	5,75	6,72	6,82	5,58	7,12	8,43	10,17	10,91
Cooling sensible emission	kW	1,54	1,94	2,34	2,62	2,62	2,44	2,98	3,51	4,09	4,48	2,92	3,73	4,51	5,33	5,54	4,09	5,39	6,57	8,07	9,00
Heating emission	kW	2,19	2,82	3,44	3,88	3,88	3,56	4,43	5,27	6,22	6,87	4,19	5,45	6,66	7,98	8,35	5,57	7,43	9,14	11,30	12,69
Dp Cooling	kPa	20,8	30,2	40,7	48,4	48,4	15,9	21,8	28,1	35,7	41,1	12,4	18,3	24,6	32,0	34,1	11,8	18,3	25,0	34,3	40,8
Dp Heating	kPa	19,2	30,1	43,1	53,7	53,7	15,0	22,2	30,3	40,9	48,9	11,1	17,9	25,7	35,6	38,5	9,5	15,9	23,1	33,9	41,7
Motor power input	W	14	21	37	54	54	21	33	54	92	132	20	34	57	101	136	29	55	98	173	277
Sound power (Lw)	dB(A)	41	48	54	58	58	44	50	55	60	64	44	51	57	63	64	48	56	61	67	70
Sound pressure (Lp) ⁽¹⁾	dB(A)	32	39	45	49	49	35	41	46	51	55	35	42	48	54	55	39	47	52	58	61

(1) The sound pressure levels are 9 dB (A) lower than the sound power levels, apply to the reverberant field of a 100 m³ room and a reverberation time of 0.5 sec.

Note: for the sound pressure levels with available pressure different from 0 Pa, contact the Sabiana technical sales department.

4 row coil unit - 2 pipe models

The following standard rating conditions are used:

COOLING

Entering air temperature: + 27 °C d.b. + 19 °C w.b.
Water temperature: +7 °C E.W.T. +12 °C L.W.T.

HEATING

Entering air temperature: + 20 °C
Water temperature: +45 °C E.W.T. +40 °C L.W.T.

Available pressure: 0 Pa

MODEL	Speed	CRSL-ECM 14					CRSL-ECM 24					CRSL-ECM 44					CRSL-ECM 74				
		1	3	5	7,5	10	1	3	5	7,5	10	1	3	5	7,5	10	1	3	5	7,5	10
		MIN		MED		MAX	MIN		MED		MAX	MIN		MED		MAX	MIN		MED		MAX
Air flow	m ³ /h	330	440	560	650	650	550	710	880	1085	1235	615	830	1055	1315	1390	880	1240	1605	2110	2460
Cooling total emission	kW	2,33	2,92	3,48	3,91	3,85	3,87	4,70	5,48	6,41	6,87	4,21	5,29	6,27	7,38	7,52	6,03	7,81	9,36	11,40	12,32
Cooling sensible emission	kW	1,67	2,13	2,60	2,93	2,93	2,75	3,40	4,04	4,76	5,25	3,05	3,93	4,77	5,67	5,90	4,34	5,78	7,10	8,79	9,83
Heating emission	kW	2,33	3,02	3,75	4,27	4,27	3,86	4,86	5,88	7,03	7,82	4,32	5,67	6,99	8,44	8,83	6,14	8,35	10,45	13,16	14,91
Dp Cooling	kPa	11,6	17,5	24,1	29,2	29,2	25,4	36,1	47,8	62,3	73,1	8,1	12,2	16,7	22,0	23,5	9,6	15,3	21,3	29,9	35,7
Dp Heating	kPa	11,3	18,1	26,7	33,7	33,7	21,2	32,1	45,2	62,5	75,6	6,8	11,1	16,3	22,8	24,8	8,6	15,0	22,5	34,0	42,6
Motor power input	W	14	21	37	54	54	21	33	54	92	132	20	34	57	101	136	29	55	98	173	277
Sound power (Lw)	dB(A)	41	48	54	58	58	44	50	55	60	64	44	51	57	63	64	48	56	61	67	70
Sound pressure (Lp) ⁽¹⁾	dB(A)	32	39	45	49	49	35	41	46	51	55	35	42	48	54	55	39	47	52	58	61

(1) The sound pressure levels are 9 dB (A) lower than the sound power levels, apply to the reverberant field of a 100 m³ room and a reverberation time of 0.5 sec.

Note: for the sound pressure levels with available pressure different from 0 Pa, contact the Sabiana technical sales department.

3+1 row coil unit - 4 pipe models

The following standard rating conditions are used:

COOLING

Entering air temperature: + 27 °C d.b. + 19 °C w.b.
Water temperature: +7 °C E.W.T. +12 °C L.W.T.

HEATING

Entering air temperature: + 20 °C
Water temperature: +65 °C E.W.T. +55 °C L.W.T.

Available pressure: 0 Pa

MODEL	Speed	CRSL-ECM 13+1					CRSL-ECM 23+1					CRSL-ECM 43+1					CRSL-ECM 73+1				
		1 MIN	3	5 MED	7,5	10 MAX	1 MIN	3	5 MED	7,5	10 MAX	1 MIN	3	5 MED	7,5	10 MAX	1 MIN	3	5 MED	7,5	10 MAX
Air flow	m ³ /h	330	440	560	650	650	550	710	880	1085	1235	615	830	1055	1315	1390	880	1240	1605	2110	2460
Cooling total emission	kW	2,11	2,59	3,04	3,39	3,34	3,27	3,89	4,46	5,15	5,44	3,95	4,89	5,75	6,72	6,82	5,58	7,12	8,43	10,17	10,91
Cooling sensible emission	kW	1,54	1,94	2,34	2,62	2,62	2,44	2,98	3,51	4,09	4,48	2,92	3,73	4,51	5,33	5,54	4,09	5,39	6,57	8,07	9,00
Heating emission	kW	1,82	2,20	2,57	2,82	2,82	2,78	3,27	3,75	4,28	4,64	3,16	3,85	4,49	5,17	5,35	4,64	5,80	6,85	8,16	8,97
Dp Cooling	kPa	20,8	30,2	40,7	48,4	48,4	15,9	21,8	28,1	35,7	41,1	12,4	18,3	24,6	32,0	34,1	11,8	18,3	25,0	34,3	40,8
Dp Heating	kPa	8,0	11,2	14,9	17,6	17,6	4,1	5,5	7,1	9,0	10,4	5,1	7,3	9,6	12,4	13,2	10,2	15,3	20,7	28,3	33,6
Motor power input	W	14	21	37	54	54	21	33	54	92	132	20	34	57	101	136	29	55	98	173	277
Sound power (Lw)	dB(A)	41	48	54	58	58	44	50	55	60	64	44	51	57	63	64	48	56	61	67	70
Sound pressure (Lp) ⁽¹⁾	dB(A)	32	39	45	49	49	35	41	46	51	55	35	42	48	54	55	39	47	52	58	61

(1) The sound pressure levels are 9 dB (A) lower than the sound power levels, apply to the reverberant field of a 100 m³ room and a reverberation time of 0.5 sec.

Note: for the sound pressure levels with available pressure different from 0 Pa, contact the Sabiana technical sales department.

COOLING EMISSION

3 row coil unit

Entering air temperature: 27 °C - R.H.: 50% - Available pressure: 0 Pa

Model	Speed		WT: 7 / 12 °C					WT: 8 / 13 °C					WT: 10 / 15 °C					WT: 12 / 17 °C				
			Qv m³/h	Pc kW	Ps kW	Qw l/h	Dp(c) kPa	Pc kW	Ps kW	Qw l/h	Dp(c) kPa	Pc kW	Ps kW	Qw l/h	Dp(c) kPa	Pc kW	Ps kW	Qw l/h	Dp(c) kPa			
CRSL-ECM 13	10	MAX	650	3,67	2,63	631	55,7	3,28	2,50	565	45,4	2,55	2,28	438	28,5	1,90	1,90	328	16,7			
	7,5		650	3,72	2,63	640	55,7	3,34	2,50	574	45,4	2,60	2,28	447	28,5	1,96	1,90	337	16,7			
	5	MED	560	3,32	2,35	571	46,6	2,98	2,22	512	38,1	2,30	2,02	396	23,8	1,71	1,71	295	13,8			
	3		440	2,82	1,95	485	34,7	2,53	1,84	436	28,5	1,95	1,65	335	17,6	1,44	1,44	247	10,1			
	1	MIN	330	2,28	1,55	393	23,7	2,06	1,46	354	19,6	1,58	1,29	272	12,1	1,16	1,15	199	6,8			
CRSL-ECM 23	10	MAX	1235	6,01	4,48	1034	47,1	5,38	4,31	926	38,4	4,21	4,00	724	24,5	3,20	3,20	550	14,8			
	7,5		1085	5,65	4,08	971	40,9	5,06	3,90	871	33,3	3,97	3,61	682	21,1	3,02	2,93	520	12,6			
	5	MED	880	4,87	3,50	838	32,3	4,36	3,33	750	26,3	3,38	3,04	582	16,5	2,53	2,53	435	9,7			
	3		710	4,23	2,98	728	25,1	3,79	2,82	652	20,5	2,93	2,55	503	12,7	2,17	2,17	374	7,4			
	1	MIN	550	3,55	2,45	611	18,3	3,19	2,30	548	15,0	2,45	2,06	422	9,2	1,81	1,81	311	5,3			
CRSL-ECM 43	10	MAX	1390	7,53	5,56	1294	39,2	6,72	5,31	1156	31,9	5,22	4,85	897	20,0	3,92	3,92	675	11,9			
	7,5		1315	7,37	5,33	1268	36,8	6,60	5,08	1135	29,9	5,13	4,63	883	18,7	3,87	3,77	666	11,0			
	5	MED	1055	6,31	4,50	1084	28,5	5,62	4,27	967	23,1	4,34	3,86	746	14,4	3,22	3,22	555	8,3			
	3		830	5,35	3,73	920	21,2	4,77	3,52	820	17,2	3,67	3,15	631	10,6	2,70	2,70	465	6,1			
	1	MIN	615	4,29	2,93	739	14,3	3,85	2,76	662	11,7	2,95	2,44	507	7,2	2,15	2,15	371	4,0			
CRSL-ECM 73	10	MAX	2460	12,08	9,00	2078	46,8	10,79	8,65	1857	38,0	8,43	8,02	1449	24,1	6,39	6,39	1098	14,5			
	7,5		2110	11,15	8,04	1918	39,4	9,99	7,69	1718	32,0	7,81	7,09	1343	20,2	5,92	5,75	1018	12,0			
	5	MED	1605	9,22	6,57	1586	28,8	8,24	6,23	1418	23,4	6,36	5,67	1095	14,6	4,75	4,75	816	8,5			
	3		1240	7,74	5,39	1332	21,0	6,94	5,09	1194	17,2	5,33	4,58	917	10,6	3,94	3,94	677	6,1			
	1	MIN	880	6,04	4,10	1039	13,4	5,44	3,86	935	11,1	4,17	3,43	716	6,8	3,04	3,04	523	3,8			

- WT:** Water temperature
- Qv:** Air flow
- Pc:** Cooling total emission
- Ps:** Cooling sensible emission
- Qw:** Water flow rate
- Dp(c):** Dp Cooling

Note: the power absorption (Watt) at p. 47 must be subtracted from the total and sensible cooling emission

Entering air temperature: 26 °C - R.H.: 50% - Available pressure: 0 Pa

Model	Speed		Qv m ³ /h	WT: 7 / 12 °C				WT: 8 / 13 °C				WT: 10 / 15 °C				WT: 12 / 17 °C			
				Pc kW	Ps kW	Qw l/h	Dp(c) kPa	Pc kW	Ps kW	Qw l/h	Dp(c) kPa	Pc kW	Ps kW	Qw l/h	Dp(c) kPa	Pc kW	Ps kW	Qw l/h	Dp(c) kPa
CRSL-ECM 13	10	MAX	650	3,27	2,50	562	45,2	2,89	2,38	498	36,2	2,21	2,17	381	22,2	1,63	1,63	281	12,7
	7,5		650	3,32	2,50	571	45,2	2,95	2,38	507	36,2	2,27	2,17	390	22,2	1,69	1,63	290	12,7
	5	MED	560	2,96	2,23	510	37,9	2,62	2,12	451	30,3	2,00	1,92	344	18,4	1,46	1,46	252	10,4
	3		440	2,52	1,84	433	28,3	2,23	1,74	383	22,6	1,68	1,56	290	13,5	1,22	1,22	210	7,5
	1	MIN	330	2,05	1,46	352	19,5	1,81	1,37	311	15,5	1,36	1,22	234	9,2	0,98	0,98	168	5,0
CRSL-ECM 23	10	MAX	1235	5,35	4,30	921	38,3	4,76	4,14	820	30,9	3,69	3,69	634	19,3	2,76	2,76	476	11,4
	7,5		1085	5,04	3,91	868	33,2	4,48	3,75	771	26,7	3,48	3,39	598	16,5	2,62	2,53	450	9,7
	5	MED	880	4,34	3,33	747	26,2	3,84	3,18	661	21,0	2,94	2,91	506	12,9	2,17	2,17	374	7,4
	3		710	3,78	2,82	649	20,4	3,34	2,68	574	16,3	2,54	2,43	436	9,8	1,86	1,86	319	5,6
	1	MIN	550	3,17	2,31	545	14,9	2,80	2,18	482	11,9	2,12	1,95	364	7,1	1,53	1,53	264	3,9
CRSL-ECM 43	10	MAX	1390	6,69	5,31	1151	31,7	5,94	5,07	1021	25,5	4,55	4,55	783	15,6	3,37	3,37	580	9,0
	7,5		1315	6,56	5,08	1128	29,8	5,83	4,85	1003	23,9	4,48	4,38	771	14,6	3,34	3,24	574	8,4
	5	MED	1055	5,59	4,28	962	23,0	4,95	4,06	851	18,3	3,77	3,66	648	11,1	2,75	2,75	474	6,3
	3		830	4,74	3,53	816	17,1	4,19	3,34	721	13,6	3,17	2,98	545	8,2	2,30	2,30	395	4,5
	1	MIN	615	3,82	2,76	658	11,6	3,38	2,60	581	9,2	2,54	2,30	437	5,5	1,82	1,82	313	3,0
CRSL-ECM 73	10	MAX	2460	10,75	8,65	1848	37,9	9,54	8,31	1641	30,4	7,37	7,37	1268	19,0	5,52	5,52	949	11,2
	7,5		2110	9,94	7,69	1710	31,9	8,84	7,37	1521	25,6	6,83	6,66	1175	15,8	5,13	4,95	882	9,2
	5	MED	1605	8,21	6,24	1411	23,3	7,25	5,94	1248	18,6	5,52	5,40	950	11,3	4,06	4,06	699	6,4
	3		1240	6,91	5,10	1188	17,1	6,10	4,83	1049	13,6	4,61	4,34	793	8,2	3,35	3,35	577	4,6
	1	MIN	880	5,40	3,87	929	11,0	4,77	3,64	820	8,7	3,58	3,23	616	5,2	2,57	2,57	442	2,8

WT: Water temperature
Qv: Air flow
Pc: Cooling total emission
Ps: Cooling sensible emission
Qw: Water flow rate
Dp(c): Dp Cooling

Note: the power absorption (Watt) at p. 47 must be subtracted from the total and sensible cooling emission

Entering air temperature: 25 °C - R.H.: 50% - Available pressure: 0 Pa

Model	Speed		WT: 7 / 12 °C					WT: 8 / 13 °C				WT: 10 / 15 °C				WT: 12 / 17 °C			
			Qv m ³ /h	Pc kW	Ps kW	Qw l/h	Dp(c) kPa	Pc kW	Ps kW	Qw l/h	Dp(c) kPa	Pc kW	Ps kW	Qw l/h	Dp(c) kPa	Pc kW	Ps kW	Qw l/h	Dp(c) kPa
CRSL-ECM 13	10	MAX	650	2,88	2,38	496	36,1	2,54	2,27	437	28,6	1,92	1,92	330	17,1	1,41	1,41	242	9,7
	7,5		650	2,94	2,38	505	36,1	2,59	2,27	446	28,6	1,97	1,92	339	17,1	1,46	1,41	252	9,7
	5	MED	560	2,61	2,12	450	30,3	2,30	2,01	395	23,9	1,73	1,73	297	14,1	1,24	1,24	213	7,7
	3		440	2,22	1,74	381	22,5	1,94	1,65	334	17,7	1,45	1,45	249	10,3	1,03	1,03	177	5,5
	1	MIN	330	1,80	1,38	310	15,5	1,57	1,29	271	12,1	1,17	1,15	200	7,0	0,82	0,82	141	3,6
CRSL-ECM 23	10	MAX	1235	4,75	4,14	817	30,9	4,20	3,98	723	24,6	3,22	3,22	553	15,1	2,65	2,65	455	10,5
	7,5		1085	4,48	3,74	770	26,7	3,96	3,59	682	21,2	3,04	2,95	523	12,9	2,42	2,33	417	8,4
	5	MED	880	3,83	3,18	659	20,9	3,37	3,03	580	16,6	2,55	2,55	439	9,9	1,90	1,90	327	5,8
	3		710	3,32	2,68	572	16,2	2,92	2,55	502	12,8	2,19	2,19	377	7,5	1,57	1,57	271	4,1
	1	MIN	550	2,79	2,19	480	11,8	2,44	2,06	420	9,3	1,82	1,82	313	5,4	1,29	1,29	222	2,9
CRSL-ECM 43	10	MAX	1390	5,92	5,06	1018	25,5	5,21	4,83	897	20,2	3,95	3,95	679	12,1	3,27	3,27	563	8,6
	7,5		1315	5,81	4,85	1000	23,9	5,13	4,62	882	18,9	3,90	3,80	671	11,3	3,20	3,10	551	7,8
	5	MED	1055	4,93	4,06	849	18,3	4,33	3,85	744	14,4	3,25	3,25	559	8,5	2,50	2,50	431	5,3
	3		830	4,18	3,34	719	13,6	3,66	3,15	630	10,7	2,73	2,73	469	6,2	1,99	1,99	342	3,5
	1	MIN	615	3,36	2,60	579	9,2	2,94	2,44	506	7,2	2,17	2,16	374	4,1	1,52	1,52	261	2,1
CRSL-ECM 73	10	MAX	2460	9,52	8,30	1637	30,5	8,41	7,98	1447	24,3	6,43	6,43	1106	14,8	5,41	5,41	931	10,8
	7,5		2110	8,82	7,37	1517	25,6	7,79	7,05	1340	20,3	5,96	5,79	1025	12,3	4,83	4,66	831	8,2
	5	MED	1605	7,24	5,94	1245	18,6	6,35	5,65	1092	14,6	4,78	4,78	822	8,7	3,58	3,58	615	5,1
	3		1240	6,07	4,83	1044	13,6	5,32	4,57	915	10,6	3,97	3,97	682	6,2	2,83	2,83	487	3,4
	1	MIN	880	4,75	3,65	817	8,7	4,15	3,43	714	6,8	3,06	3,04	527	3,9	2,15	2,15	370	2,0

- WT:** Water temperature
- Qv:** Air flow
- Pc:** Cooling total emission
- Ps:** Cooling sensible emission
- Qw:** Water flow rate
- Dp(c):** Dp Cooling

Note: the power absorption (Watt) at p. 47 must be subtracted from the total and sensible cooling emission

4 row coil unit

Entering air temperature: 27 °C - R.H.: 50% - Available pressure: 0 Pa

Model	Speed	Qv m ³ /h	WT: 7 / 12 °C				WT: 8 / 13 °C				WT: 10 / 15 °C				WT: 12 / 17 °C				
			Pc kW	Ps kW	Qw l/h	Dp(c) kPa	Pc kW	Ps kW	Qw l/h	Dp(c) kPa	Pc kW	Ps kW	Qw l/h	Dp(c) kPa	Pc kW	Ps kW	Qw l/h	Dp(c) kPa	
CRSL-ECM 14	10	MAX	650	4,24	2,96	730	33,9	3,79	2,79	651	27,5	2,91	2,49	501	17,0	2,15	2,15	369	9,7
	7,5		650	4,30	2,96	739	33,9	3,84	2,79	660	27,5	2,97	2,49	510	17,0	2,20	2,15	379	9,7
	5	MED	560	3,81	2,62	655	27,9	3,40	2,47	586	22,7	2,62	2,20	450	14,0	1,92	1,92	330	7,9
	3		440	3,17	2,15	546	20,1	2,85	2,02	490	16,5	2,19	1,78	376	10,1	1,59	1,57	274	5,7
	1	MIN	330	2,52	1,68	434	13,3	2,28	1,58	391	11,0	1,75	1,38	300	6,8	1,27	1,21	218	3,7
CRSL-ECM 24	10	MAX	1235	7,56	5,32	1300	83,9	6,78	5,04	1167	68,8	5,26	4,55	904	43,0	3,91	3,91	673	25,1
	7,5		1085	7,00	4,81	1204	71,4	6,30	4,54	1084	58,6	4,90	4,08	842	36,6	3,65	3,56	628	21,2
	5	MED	880	5,95	4,08	1024	54,6	5,37	3,84	923	45,1	4,14	3,42	711	28,0	3,04	3,04	524	16,0
	3		710	5,07	3,42	873	40,9	4,59	3,22	789	34,0	3,53	2,85	608	21,0	2,58	2,52	444	11,9
	1	MIN	550	4,16	2,76	715	28,6	3,77	2,60	649	23,9	2,91	2,28	500	14,8	2,11	2,00	364	8,3
CRSL-ECM 44	10	MAX	1390	8,32	5,96	1431	27,3	7,42	5,65	1276	22,1	5,72	5,10	983	13,7	4,25	4,25	731	8,0
	7,5		1315	8,11	5,70	1396	25,5	7,24	5,40	1245	20,6	5,60	4,86	964	12,8	4,18	4,08	719	7,4
	5	MED	1055	6,87	4,79	1182	19,4	6,13	4,52	1054	15,7	4,71	4,04	810	9,7	3,47	3,47	596	5,5
	3		830	5,77	3,95	992	14,1	5,16	3,71	887	11,5	3,95	3,29	680	7,1	2,89	2,89	497	4,0
	1	MIN	615	4,57	3,07	786	9,3	4,11	2,88	706	7,6	3,15	2,53	541	4,7	2,28	2,23	392	2,6
CRSL-ECM 74	10	MAX	2460	13,64	9,91	2346	41,2	12,17	9,45	2093	33,4	9,44	8,62	1623	20,9	7,07	7,07	1215	12,3
	7,5		2110	12,53	8,83	2154	34,5	11,21	8,39	1928	28,0	8,69	7,60	1495	17,4	6,51	6,34	1121	10,1
	5	MED	1605	10,24	7,14	1761	24,6	9,15	6,74	1575	20,0	7,04	6,04	1211	12,4	5,19	5,19	893	7,1
	3		1240	8,50	5,81	1461	17,6	7,62	5,47	1311	14,4	5,84	4,85	1005	8,8	4,28	4,28	736	5,0
	1	MIN	880	6,52	4,37	1122	10,9	5,88	4,10	1012	9,0	4,50	3,60	775	5,5	3,27	3,17	562	3,1

WT: Water temperature
Qv: Air flow
Pc: Cooling total emission
Ps: Cooling sensible emission
Qw: Water flow rate
Dp(c): Dp Cooling

Note: the power absorption (Watt) at p. 47 must be subtracted from the total and sensible cooling emission

Entering air temperature: 26 °C - R.H.: 50% - Available pressure: 0 Pa

Model	Speed		WT: 7 / 12 °C					WT: 8 / 13 °C				WT: 10 / 15 °C				WT: 12 / 17 °C			
			Qv m ³ /h	Pc kW	Ps kW	Qw l/h	Dp(c) kPa	Pc kW	Ps kW	Qw l/h	Dp(c) kPa	Pc kW	Ps kW	Qw l/h	Dp(c) kPa	Pc kW	Ps kW	Qw l/h	Dp(c) kPa
CRSL-ECM 14	10	MAX	650	3,77	2,80	648	27,3	3,33	2,64	572	21,8	2,52	2,36	433	13,1	1,82	1,82	314	7,2
	7,5		650	3,82	2,80	657	27,3	3,38	2,64	582	21,8	2,57	2,36	443	13,1	1,88	1,82	323	7,2
	5	MED	560	3,38	2,48	582	22,5	2,99	2,33	514	18,0	2,26	2,07	388	10,7	1,63	1,63	280	5,9
	3		440	2,83	2,03	487	16,4	2,50	1,90	430	13,0	1,88	1,68	324	7,7	1,34	1,34	231	4,2
	1	MIN	330	2,26	1,59	389	10,9	2,00	1,48	344	8,7	1,50	1,30	258	5,1	1,06	1,06	182	2,7
CRSL-ECM 24	10	MAX	1235	6,75	5,05	1161	68,4	5,98	4,79	1028	54,8	4,56	4,32	785	33,3	3,34	3,34	575	18,9
	7,5		1085	6,27	4,55	1079	58,4	5,57	4,31	957	46,7	4,26	3,87	732	28,3	3,12	3,03	537	15,8
	5	MED	880	5,34	3,85	918	44,8	4,72	3,63	812	35,8	3,58	3,23	615	21,5	2,58	2,58	444	11,9
	3		710	4,56	3,23	785	33,8	4,04	3,04	694	27,0	3,05	2,68	524	16,1	2,18	2,18	375	8,8
	1	MIN	550	3,74	2,61	644	23,7	3,32	2,44	572	19,0	2,50	2,14	430	11,3	1,77	1,77	305	6,0
CRSL-ECM 44	10	MAX	1390	7,37	5,66	1268	22,0	6,53	5,37	1122	17,5	4,96	4,84	853	10,6	3,63	3,63	624	6,0
	7,5		1315	7,20	5,41	1239	20,5	6,38	5,13	1097	16,4	4,87	4,61	837	9,9	3,58	3,48	616	5,6
	5	MED	1055	6,10	4,53	1049	15,6	5,39	4,28	926	12,4	4,07	3,82	700	7,4	2,94	2,94	506	4,1
	3		830	5,13	3,72	882	11,4	4,53	3,50	779	9,1	3,41	3,10	586	5,4	2,44	2,44	419	2,9
	1	MIN	615	4,08	2,89	702	7,6	3,60	2,71	620	6,0	2,70	2,37	465	3,6	1,92	1,92	330	1,9
CRSL-ECM 74	10	MAX	2460	12,12	9,46	2084	33,3	10,73	9,02	1846	26,6	8,21	8,21	1412	16,3	6,07	6,07	1043	9,4
	7,5		2110	11,14	8,39	1916	27,8	9,88	7,98	1699	22,2	7,57	7,22	1301	13,5	5,60	5,42	963	7,7
	5	MED	1605	9,10	6,75	1566	19,9	8,04	6,38	1384	15,9	6,09	5,72	1047	9,5	4,42	4,42	760	5,3
	3		1240	7,58	5,48	1304	14,3	6,69	5,16	1151	11,4	5,04	4,57	866	6,8	3,62	3,62	622	3,7
	1	MIN	880	5,85	4,11	1005	9,0	5,16	3,86	888	7,1	3,87	3,38	665	4,2	2,75	2,75	472	2,2

- WT:** Water temperature
- Qv:** Air flow
- Pc:** Cooling total emission
- Ps:** Cooling sensible emission
- Qw:** Water flow rate
- Dp(c):** Dp Cooling

Note: the power absorption (Watt) at p. 47 must be subtracted from the total and sensible cooling emission

Entering air temperature: 25 °C - R.H.: 50% - Available pressure: 0 Pa

Model	Speed		Qv m ³ /h	WT: 7 / 12 °C				WT: 8 / 13 °C				WT: 10 / 15 °C				WT: 12 / 17 °C			
				Pc kW	Ps kW	Qw l/h	Dp(c) kPa	Pc kW	Ps kW	Qw l/h	Dp(c) kPa	Pc kW	Ps kW	Qw l/h	Dp(c) kPa	Pc kW	Ps kW	Qw l/h	Dp(c) kPa
CRSL-ECM 14	10	MAX	650	3,32	2,64	570	21,7	2,91	2,49	500	17,1	2,16	2,16	372	9,9	1,56	1,56	268	5,4
	7,5		650	3,37	2,64	580	21,7	2,96	2,49	509	17,1	2,22	2,16	381	9,9	1,61	1,56	277	5,4
	5	MED	560	2,98	2,34	513	17,9	2,61	2,20	449	14,0	1,93	1,93	333	8,1	1,36	1,36	234	4,3
	3		440	2,49	1,91	428	13,0	2,18	1,79	375	10,2	1,61	1,57	276	5,8	1,12	1,12	192	3,0
	1	MIN	330	1,99	1,49	342	8,7	1,74	1,39	299	6,8	1,28	1,21	219	3,8	0,87	0,87	150	1,9
CRSL-ECM 24	10	MAX	1235	5,96	4,79	1026	54,8	5,24	4,54	902	43,3	3,94	3,94	678	25,6	2,83	2,83	486	13,9
	7,5		1085	5,55	4,32	954	46,7	4,88	4,08	840	36,8	3,68	3,59	633	21,6	2,65	2,56	455	11,6
	5	MED	880	4,70	3,64	809	35,7	4,13	3,43	710	28,1	3,07	3,04	528	16,3	2,16	2,16	372	8,6
	3		710	4,02	3,04	692	26,9	3,52	2,86	606	21,1	2,61	2,52	448	12,2	1,82	1,82	312	6,3
	1	MIN	550	3,31	2,45	569	19,0	2,90	2,29	498	14,9	2,13	2,00	366	8,5	1,47	1,47	252	4,3
CRSL-ECM 44	10	MAX	1390	6,50	5,37	1118	17,5	5,71	5,09	982	13,8	4,28	4,28	736	8,1	3,33	3,33	572	5,1
	7,5		1315	6,36	5,13	1093	16,3	5,60	4,86	962	12,9	4,21	4,11	724	7,6	3,25	3,15	560	4,7
	5	MED	1055	5,37	4,28	923	12,4	4,70	4,04	808	9,7	3,49	3,49	600	5,6	2,55	2,55	438	3,2
	3		830	4,51	3,50	775	9,1	3,94	3,29	678	7,1	2,91	2,91	501	4,1	2,04	2,04	350	2,1
	1	MIN	615	3,59	2,72	617	6,0	3,13	2,54	539	4,7	2,30	2,22	396	2,7	1,59	1,59	273	1,3
CRSL-ECM 74	10	MAX	2460	10,70	9,01	1840	26,6	9,42	8,59	1621	21,1	7,12	7,12	1224	12,6	5,63	5,63	968	8,2
	7,5		2110	9,86	7,98	1695	22,2	8,67	7,58	1491	17,5	6,56	6,39	1129	10,4	5,03	4,85	865	6,3
	5	MED	1605	8,02	6,39	1380	15,8	7,02	6,04	1208	12,4	5,23	5,23	900	7,2	3,73	3,73	641	3,9
	3		1240	6,66	5,17	1146	11,3	5,83	4,86	1002	8,9	4,31	4,31	741	5,1	3,02	3,02	520	2,7
	1	MIN	880	5,14	3,86	883	7,1	4,49	3,62	773	5,6	3,29	3,17	567	3,1	2,27	2,27	391	1,6

WT: Water temperature
Qv: Air flow
Pc: Cooling total emission
Ps: Cooling sensible emission
Qw: Water flow rate
Dp(c): Dp Cooling

Note: the power absorption (Watt) at p. 47 must be subtracted from the total and sensible cooling emission

HEATING EMISSION

3 row coil unit

Entering air temperature: 20 °C - Available pressure: 0 Pa

Model	Speed		WT: 70 / 60 °C			WT: 60 / 50 °C			WT: 55 / 45 °C			WT: 50 / 40 °C			WT: 50 / 45 °C			WT: 45 / 40 °C			
			Qv m ³ /h	Ph kW	Qw l/h	Dp(h) kPa	Ph kW	Qw l/h	Dp(h) kPa	Ph kW	Qw l/h	Dp(h) kPa	Ph kW	Qw l/h	Dp(h) kPa	Ph kW	Qw l/h	Dp(h) kPa	Ph kW	Qw l/h	Dp(h) kPa
CRSL-ECM 13	10	MAX	650	7,82	672	50,2	6,00	516	32,2	5,09	438	24,4	4,17	359	17,4	4,79	823	76,8	3,88	668	53,7
	7,5		650	7,82	672	50,2	6,00	516	32,2	5,09	438	24,4	4,17	359	17,4	4,79	823	76,8	3,88	668	53,7
	5	MED	560	6,93	596	40,4	5,31	457	25,9	4,51	388	19,6	3,70	319	14,0	4,24	729	61,8	3,44	591	43,1
	3		440	5,66	487	28,1	4,34	374	18,0	3,69	317	13,7	3,03	261	9,8	3,47	596	43,0	2,82	484	30,1
	1	MIN	330	4,41	380	17,9	3,40	292	11,6	2,89	248	8,8	2,37	204	6,3	2,70	465	27,5	2,19	377	19,2
CRSL-ECM 23	10	MAX	1235	13,86	1192	45,9	10,62	913	29,4	8,99	773	22,2	7,37	634	15,8	8,49	1460	70,2	6,87	1182	48,9
	7,5		1085	12,53	1078	38,3	9,60	826	24,5	8,14	700	18,5	6,67	573	13,2	7,68	1321	58,6	6,22	1070	40,9
	5	MED	880	10,63	914	28,4	8,14	700	18,2	6,90	594	13,8	5,67	487	9,8	6,50	1118	43,4	5,27	906	30,3
	3		710	8,90	765	20,7	6,84	588	13,3	5,79	498	10,0	4,75	409	7,2	5,45	938	31,6	4,43	761	22,2
	1	MIN	550	7,17	616	14,0	5,52	474	9,0	4,67	402	6,8	3,84	331	4,9	4,39	755	21,4	3,56	613	15,0
CRSL-ECM 43	10	MAX	1390	16,83	1447	36,1	12,88	1108	23,1	10,92	939	17,5	8,92	767	12,4	10,32	1775	55,4	8,35	1436	38,5
	7,5		1315	16,10	1384	33,3	12,32	1060	21,3	10,45	899	16,1	8,54	735	11,4	9,86	1697	51,1	7,98	1373	35,6
	5	MED	1055	13,43	1155	24,1	10,30	886	15,5	8,72	750	11,7	7,15	615	8,3	8,23	1415	36,9	6,66	1146	25,7
	3		830	10,98	944	16,7	8,41	723	10,7	7,13	613	8,1	5,85	503	5,8	6,72	1155	25,6	5,45	937	17,9
	1	MIN	615	8,44	725	10,4	6,47	557	6,7	5,50	473	5,1	4,52	388	3,6	5,16	887	15,9	4,19	720	11,1
CRSL-ECM 73	10	MAX	2460	25,63	2204	39,2	19,60	1686	25,0	16,56	1424	18,8	13,56	1166	13,4	15,69	2699	60,0	12,69	2183	41,7
	7,5		2110	22,78	1959	31,7	17,45	1501	20,3	14,76	1269	15,3	12,07	1038	10,8	13,96	2401	48,6	11,30	1944	33,9
	5	MED	1605	18,43	1585	21,7	14,12	1214	13,9	11,95	1027	10,4	9,78	841	7,4	11,28	1940	33,1	9,14	1572	23,1
	3		1240	14,93	1284	14,8	11,46	985	9,5	9,71	835	7,2	7,96	684	5,1	9,16	1575	22,7	7,43	1277	15,9
	1	MIN	880	11,22	965	8,9	8,62	741	5,7	7,32	629	4,3	5,99	516	3,1	6,87	1182	13,6	5,57	959	9,5

WT: Water temperature
Qv: Air flow
Ph: Heating emission
Qw: Water flow rate
Dp(h): Dp Heating

4 row coil unit

Entering air temperature: 20 °C - Available pressure: 0 Pa

Model	Speed	Qv m ³ /h	WT: 70 / 60 °C			WT: 60 / 50 °C			WT: 55 / 45 °C			WT: 50 / 40 °C			WT: 50 / 45 °C			WT: 45 / 40 °C			
			Ph kW	Qw l/h	Dp(h) kPa	Ph kW	Qw l/h	Dp(h) kPa	Ph kW	Qw l/h	Dp(h) kPa	Ph kW	Qw l/h	Dp(h) kPa	Ph kW	Qw l/h	Dp(h) kPa	Ph kW	Qw l/h	Dp(h) kPa	
CRSL-ECM 14	10	MAX	650	8,57	737	31,4	6,59	566	20,2	5,58	480	15,3	4,59	395	10,9	5,25	904	48,1	4,27	734	33,7
	7,5		650	8,57	737	31,4	6,59	566	20,2	5,58	480	15,3	4,59	395	10,9	5,25	904	48,1	4,27	734	33,7
	5	MED	560	7,53	648	24,9	5,79	498	16,0	4,91	423	12,1	4,04	347	8,7	4,62	795	38,1	3,75	645	26,7
	3		440	6,08	523	16,9	4,68	402	10,9	3,98	342	8,3	3,27	282	5,9	3,73	641	25,9	3,02	520	18,1
	1	MIN	330	4,68	402	10,5	3,60	310	6,8	3,07	264	5,2	2,53	217	3,7	2,87	493	16,1	2,33	400	11,3
CRSL-ECM 24	10	MAX	1235	15,74	1354	70,7	12,11	1041	45,6	10,30	886	34,7	8,46	728	24,8	9,63	1656	108,0	7,82	1345	75,6
	7,5		1085	14,14	1216	58,2	10,87	935	37,5	9,25	795	28,6	7,61	654	20,5	8,65	1488	89,0	7,03	1209	62,5
	5	MED	880	11,81	1016	42,1	9,08	781	27,1	7,72	664	20,6	6,36	547	14,8	7,22	1243	64,4	5,88	1011	45,2
	3		710	9,76	840	29,9	7,53	648	19,4	6,41	551	14,8	5,28	454	10,6	5,98	1029	45,8	4,86	836	32,1
	1	MIN	550	7,74	666	19,7	5,98	514	12,8	5,09	438	9,8	4,20	361	7,0	4,74	816	30,2	3,86	664	21,2
CRSL-ECM 44	10	MAX	1390	17,79	1530	23,2	13,65	1174	14,9	11,56	994	11,2	9,47	814	8,0	10,89	1873	35,5	8,83	1518	24,8
	7,5		1315	17,00	1462	21,4	13,01	1119	13,7	11,03	948	10,3	9,04	777	7,4	10,41	1790	32,7	8,44	1451	22,8
	5	MED	1055	14,06	1209	15,2	10,80	929	9,8	9,16	788	7,4	7,52	647	5,3	8,62	1483	23,3	6,99	1203	16,3
	3		830	11,39	979	10,4	8,75	752	6,7	7,44	639	5,1	6,10	524	3,6	6,98	1200	15,9	5,67	974	11,1
	1	MIN	615	8,68	746	6,4	6,68	575	4,1	5,68	488	3,1	4,67	402	2,2	5,32	914	9,8	4,32	743	6,8
CRSL-ECM 74	10	MAX	2460	30,03	2583	39,8	23,02	1980	25,5	19,50	1677	19,3	15,98	1375	13,7	18,41	3166	61,1	14,91	2565	42,6
	7,5		2110	26,52	2281	31,8	20,33	1748	20,4	17,21	1480	15,4	14,12	1215	11,0	16,24	2794	48,8	13,16	2263	34,0
	5	MED	1605	21,04	1810	21,0	16,14	1388	13,5	13,71	1179	10,2	11,25	967	7,3	12,89	2218	32,2	10,45	1798	22,5
	3		1240	16,81	1445	14,0	12,92	1111	9,0	10,97	943	6,8	9,01	775	4,9	10,28	1768	21,4	8,35	1436	15,0
	1	MIN	880	12,33	1060	8,0	9,49	817	5,2	8,07	694	3,9	6,65	572	2,8	7,55	1299	12,3	6,14	1055	8,6

WT: Water temperature
Qv: Air flow
Ph: Heating emission
Qw: Water flow rate
Dp(h): Dp Heating

1 row heating additional coil unit

For 3 or 4 row versions

Entering air temperature: 20 °C - Available pressure: 0 Pa

Model	Speed		WT: 80 / 70 °C				WT: 75 / 65 °C				WT: 70 / 60 °C				WT: 65 / 55 °C				WT: 60 / 50 °C				WT: 55 / 45 °C			
			Qv m ³ /h	Ph kW	Qw l/h	Dp(h) kPa	Ph kW	Qw l/h	Dp(h) kPa	Ph kW	Qw l/h	Dp(h) kPa	Ph kW	Qw l/h	Dp(h) kPa	Ph kW	Qw l/h	Dp(h) kPa	Ph kW	Qw l/h	Dp(h) kPa	Ph kW	Qw l/h	Dp(h) kPa		
CRSL-ECM 13+1	10	MAX	650	3,99	343	31,4	3,60	310	26,5	3,21	276	21,9	2,82	243	17,6	2,43	209	13,7	2,04	175	10,2					
	7,5		650	3,99	343	31,4	3,60	310	26,5	3,21	276	21,9	2,82	243	17,6	2,43	209	13,7	2,04	175	10,2					
	5	MED	560	3,63	312	26,5	3,27	282	22,3	2,92	251	18,5	2,57	221	14,9	2,21	190	11,6	1,86	160	8,6					
	3		440	3,11	267	20,0	2,80	241	16,9	2,50	215	13,9	2,20	189	11,2	1,89	163	8,8	1,59	137	6,5					
	1	MIN	330	2,56	220	14,1	2,32	199	12,0	2,06	177	9,9	1,82	156	8,0	1,57	135	6,2	1,32	113	4,6					
CRSL-ECM 23+1	10	MAX	1235	6,64	571	18,9	5,97	514	15,9	5,31	457	13,0	4,64	399	10,4	3,97	342	8,0	3,31	284	5,8					
	7,5		1085	6,12	526	16,3	5,50	473	13,7	4,90	421	11,3	4,28	368	9,0	3,67	315	6,9	3,05	263	5,1					
	5	MED	880	5,35	460	12,8	4,82	415	10,8	4,29	369	8,9	3,75	322	7,1	3,21	276	5,5	2,68	230	4,0					
	3		710	4,67	402	10,0	4,20	361	8,4	3,74	322	6,9	3,27	281	5,5	2,81	241	4,3	2,34	201	3,1					
	1	MIN	550	3,95	340	7,4	3,56	306	6,3	3,17	272	5,1	2,78	239	4,1	2,38	205	3,2	1,99	171	2,3					
CRSL-ECM 43+1	10	MAX	1390	7,58	652	23,6	6,84	588	19,9	6,09	524	16,4	5,35	460	13,2	4,60	395	10,2	3,85	331	7,6					
	7,5		1315	7,33	630	22,2	6,60	567	18,6	5,88	506	15,4	5,17	444	12,4	4,44	382	9,6	3,72	320	7,1					
	5	MED	1055	6,36	547	17,2	5,73	493	14,5	5,11	439	12,0	4,49	386	9,6	3,86	332	7,5	3,24	278	5,5					
	3		830	5,46	469	13,0	4,92	423	11,0	4,39	377	9,1	3,85	331	7,3	3,31	285	5,7	2,78	239	4,2					
	1	MIN	615	4,47	385	9,1	4,04	347	7,7	3,60	310	6,4	3,16	272	5,1	2,72	234	4,0	2,29	197	3,0					
CRSL-ECM 73+1	10	MAX	2460	12,67	1089	59,5	11,43	983	50,3	10,21	878	41,7	8,97	772	33,6	7,75	666	26,3	6,53	561	19,6					
	7,5		2110	11,49	988	49,9	10,38	892	42,2	9,28	798	35,1	8,16	702	28,3	7,03	605	22,1	5,94	511	16,5					
	5	MED	1605	9,64	829	36,4	8,72	750	30,9	7,78	669	25,6	6,85	589	20,7	5,92	509	16,2	4,99	429	12,1					
	3		1240	8,18	703	27,1	7,39	635	22,9	6,59	567	19,0	5,80	499	15,3	5,02	432	12,0	4,23	364	9,0					
	1	MIN	880	6,51	560	18,0	5,89	507	15,3	5,26	452	12,6	4,64	399	10,2	4,01	345	8,0	3,38	291	6,0					

WT: Water temperature
Qv: Air flow
Ph: Heating emission
Qw: Water flow rate
Dp(h): Dp Heating

2 row heating additional coil unit

3 row version only

Entering air temperature: 20 °C - Available pressure: 0 Pa

Model	Speed		WT: 65 / 55 °C				WT: 60 / 50 °C				WT: 55 / 45 °C				WT: 50 / 40 °C				WT: 45 / 40 °C				WT: 45 / 35 °C			
			Qv m ³ /h	Ph kW	Qw l/h	Dp(h) kPa	Ph kW	Qw l/h	Dp(h) kPa	Ph kW	Qw l/h	Dp(h) kPa	Ph kW	Qw l/h	Dp(h) kPa	Ph kW	Qw l/h	Dp(h) kPa	Ph kW	Qw l/h	Dp(h) kPa	Ph kW	Qw l/h	Dp(h) kPa		
CRSL-ECM 13+2	10	MAX	650	4,97	428	14,0	4,28	368	10,9	3,60	309	8,1	2,92	251	5,7	2,78	479	18,3	2,23	192	3,6					
	7,5		650	4,97	428	14,0	4,28	368	10,9	3,60	309	8,1	2,92	251	5,7	2,78	479	18,3	2,23	192	3,6					
	5	MED	560	4,47	385	11,6	3,87	333	9,1	3,25	279	6,8	2,64	227	4,7	2,51	431	15,2	2,02	173	3,0					
	3		440	3,77	324	8,5	3,25	280	6,7	2,73	235	5,0	2,22	191	3,5	2,11	363	11,1	1,70	147	2,2					
	1	MIN	330	3,04	262	5,8	2,63	226	4,5	2,21	190	3,4	1,80	155	2,4	1,71	293	7,6	1,38	119	1,5					
CRSL-ECM 23+2	10	MAX	1235	8,74	751	49,4	7,55	650	38,7	6,37	548	28,9	5,19	446	20,4	4,90	843	64,7	4,00	344	13,0					
	7,5		1085	8,01	689	42,2	6,92	595	33,0	5,83	502	24,7	4,75	409	17,4	4,50	773	55,3	3,67	315	11,1					
	5	MED	880	6,91	595	32,4	5,98	515	25,4	5,05	435	19,1	4,11	354	13,4	3,88	668	42,5	3,18	273	8,6					
	3		710	5,93	510	24,6	5,14	442	19,4	4,34	373	14,5	3,54	304	10,2	3,33	573	32,3	2,74	235	6,6					
	1	MIN	550	4,92	423	17,6	4,27	367	13,8	3,60	310	10,4	2,95	253	7,4	2,77	476	23,1	2,28	196	4,7					
CRSL-ECM 43+2	10	MAX	1390	10,37	891	71,0	8,99	774	55,9	7,60	654	42,0	6,21	534	29,8	5,83	1002	93,3	4,82	415	19,2					
	7,5		1315	9,98	858	66,3	8,65	744	52,1	7,31	629	39,2	5,98	514	27,8	5,61	965	87,1	4,64	399	17,9					
	5	MED	1055	8,54	734	50,1	7,41	637	39,5	6,28	540	29,8	5,13	441	21,1	4,80	826	65,9	3,98	342	13,6					
	3		830	7,19	619	36,8	6,23	536	28,9	5,28	454	21,8	4,32	372	15,5	4,04	696	48,4	3,36	289	10,1					
	1	MIN	615	5,76	495	24,6	4,99	429	19,4	4,22	363	14,6	3,46	298	10,4	3,23	555	32,2	2,70	232	6,8					

WT: Water temperature
Qv: Air flow
Ph: Heating emission
Qw: Water flow rate
Dp(h): Dp Heating

CORRECTION FACTOR TABLES

Air flow depending on speed and requested available pressure

Air flow (m³/h)

Model	Vdc	Available pressure (Pa)								
		0	10	20	30	40	50	60	70	80
1	10	650	636	618	595	572	543	513	481	440
	9,5	650	635	618	593	570	542	510	470	412
	9	650	634	617	592	568	540	504	450	350
	8,5	650	633	616	591	567	530	483	395	230
	8	650	632	615	590	560	516	443	282	-
	7,5	650	630	607	575	530	470	355	195	-
	7	650	627	542	550	490	405	265	-	-
	6,5	650	603	564	513	445	340	177	-	-
	6	610	575	530	473	392	262	-	-	-
	5,5	585	545	497	430	335	170	-	-	-
	5	560	514	460	385	265	50	-	-	-
	4	500	450	380	275	72	-	-	-	-
3	440	380	287	93	-	-	-	-	-	
2	380	310	170	-	-	-	-	-	-	
1	330	240	-	-	-	-	-	-	-	
2	10	1235	1203	1170	1130	1082	1030	966	886	870
	9,5	1228	1190	1148	1100	1048	900	905	808	675
	9	1218	1170	1120	1065	1000	925	830	717	656
	8,5	1170	1123	1072	1015	947	860	752	610	428
	8	1127	1080	1030	965	890	787	655	485	270
	7,5	1085	1035	980	911	825	713	563	370	-
	7	1042	992	930	857	762	635	460	220	-
	6,5	1000	946	882	800	695	545	350	-	-
	6	960	903	831	740	615	447	225	-	-
	5,5	920	860	785	682	540	345	-	-	-
	5	880	820	737	620	450	225	-	-	-
	4	795	725	625	470	245	-	-	-	-
3	710	625	485	275	-	-	-	-	-	
2	625	525	335	205	-	-	-	-	-	
1	550	425	185	-	-	-	-	-	-	
4	10	1390	1365	1350	1322	1290	1245	1180	1090	980
	9,5	1390	1360	1335	1300	1250	1190	1102	1005	905
	9	1390	1357	1315	1265	1200	1123	1035	940	832
	8,5	1390	1340	1280	1210	1140	1060	970	870	740
	8	1360	1295	1230	1160	1080	995	900	780	630
	7,5	1315	1245	1175	1100	1017	922	815	680	490
	7	1260	1190	1115	1035	950	850	725	560	260
	6,5	1200	1130	1055	970	875	760	620	415	-
	6	1155	1080	1000	910	800	680	510	240	-
	5,5	1102	1025	940	840	725	580	370	-	-
	5	1055	970	875	767	640	470	190	-	-
	4	950	85	740	610	440	150	-	-	-
3	830	725	600	430	155	-	-	-	-	
2	730	602	450	195	-	-	-	-	-	
1	615	485	280	-	-	-	-	-	-	
7	10	2460	2380	2295	2005	2115	2020	1920	1810	1700
	9,5	2390	2305	2220	2130	2035	1935	1825	1720	1600
	9	2320	2240	2140	2050	1950	1845	1740	1620	1490
	8,5	2070	2180	2095	2000	1895	1780	1665	1540	1400
	8	2220	2135	2040	1940	1835	1735	1580	1440	1290
	7,5	2110	2025	1935	1840	1725	1605	1480	1340	1180
	7	2010	1930	1840	1740	1630	1510	1380	1225	1060
	6,5	1920	1840	1750	1655	1540	1420	1290	1040	980
	6	1840	1760	1670	1575	1460	1340	1220	1060	900
	5,5	1700	1630	1550	1465	1370	1255	1120	960	785
	5	1605	1540	1465	1380	1280	1170	1025	860	675
	4	1422	1347	1265	1180	1085	980	850	660	380
3	1240	1162	1082	1000	900	780	600	305	-	
2	1070	985	900	810	700	560	360	-	-	
1	880	770	670	575	470	360	-	-	-	

Power absorption depending on air flow and available pressure

Power absorbed (Watt)

Model	Vdc	Available pressure (Pa)								
		0	10	20	30	40	50	60	70	80
1	10	54	54	55	55	55	56	55	55	54
	9,5	53	54	55	55	55	55	55	53	50
	9	53	54	55	56	56	55	54	50	42
	8,5	53	54	55	55	54	53	50	43	31
	8	54	54	54	54	53	50	45	33	-
	7,5	54	53	53	51	48	44	35	26	-
	7	54	53	47	47	43	36	28	-	-
	6,5	51	48	45	42	37	30	22	-	-
	6	46	43	40	36	31	24	-	-	-
	5,5	41	38	35	31	26	19	-	-	-
	5	37	34	31	27	21	15	-	-	-
	4	28	26	22	18	13	-	-	-	-
	3	21	19	16	12	-	-	-	-	-
2	17	15	12	-	-	-	-	-	-	
1	14	11	-	-	-	-	-	-	-	
2	10	132	130	128	125	121	116	110	103	101
	9,5	129	126	122	118	113	98	98	89	77
	9	126	120	115	109	102	94	86	76	71
	8,5	113	108	103	97	91	83	74	64	52
	8	102	97	92	86	80	72	63	53	41
	7,5	92	87	83	77	71	63	54	43	-
	7	82	79	74	69	62	54	44	34	-
	6,5	75	71	66	60	54	46	37	-	-
	6	67	63	58	52	46	38	29	-	-
	5,5	60	56	52	46	40	32	-	-	-
	5	54	50	46	40	34	27	-	-	-
	4	43	39	35	30	23	-	-	-	-
	3	33	30	25	20	-	-	-	-	-
2	26	23	19	17	-	-	-	-	-	
1	20	18	14	-	-	-	-	-	-	
4	10	136	136	136	135	134	132	129	122	112
	9,5	135	134	132	130	127	123	116	108	99
	9	134	131	127	123	117	111	104	96	87
	8,5	127	122	117	111	106	99	92	85	75
	8	117	111	106	101	94	88	81	73	63
	7,5	105	100	94	89	83	77	70	61	51
	7	94	88	83	78	72	66	59	50	36
	6,5	85	79	74	69	63	57	50	40	-
	6	77	71	65	60	55	49	41	30	-
	5,5	67	63	58	53	48	41	32	-	-
	5	60	55	51	46	40	34	25	-	-
	4	46	19	37	33	28	20	-	-	-
	3	34	30	26	22	16	-	-	-	-
2	26	23	19	15	-	-	-	-	-	
1	20	17	14	-	-	-	-	-	-	
7	10	277	271	264	237	248	239	230	219	209
	9,5	259	251	244	236	228	219	210	201	191
	9	240	233	224	217	208	200	192	182	173
	8,5	207	213	208	202	195	187	179	169	159
	8	200	197	194	189	183	176	165	155	144
	7,5	173	174	173	171	166	159	150	141	129
	7	156	158	158	156	151	145	136	126	114
	6,5	140	143	144	142	138	132	124	107	103
	6	128	131	132	131	127	120	113	103	93
	5,5	111	114	115	115	113	108	102	93	84
	5	98	101	103	104	102	99	93	84	75
	4	71	74	77	79	79	78	75	68	57
	3	55	58	61	62	63	63	59	49	-
2	41	43	46	48	49	49	44	-	-	
1	29	30	32	34	36	36	-	-	-	

Correction factors for Total cooling emission

Values in %

Model	Vdc	Available pressure (Pa)								
		0	10	20	30	40	50	60	70	80
1	10	1,00	0,99	0,97	0,94	0,92	0,88	0,85	0,81	0,76
	9,5	1,00	0,98	0,97	0,94	0,91	0,88	0,85	0,80	0,73
	9	1,00	0,98	0,97	0,94	0,91	0,88	0,84	0,77	0,64
	8,5	1,00	0,98	0,96	0,94	0,91	0,87	0,81	0,70	0,46
	8	1,00	0,98	0,96	0,94	0,90	0,85	0,77	0,54	-
	7,5	1,00	0,98	0,95	0,92	0,87	0,80	0,65	0,40	-
	7	1,00	0,98	0,88	0,89	0,82	0,72	0,52	-	-
	6,5	1,00	0,95	0,91	0,85	0,77	0,63	0,37	-	-
	6	0,96	0,92	0,87	0,80	0,70	0,51	-	-	-
	5,5	0,93	0,89	0,83	0,75	0,62	0,36	-	-	-
	5	0,90	0,85	0,79	0,69	0,52	-	-	-	-
	4	0,83	0,77	0,68	0,53	0,17	-	-	-	-
	3	0,76	0,68	0,55	0,21	-	-	-	-	-
2	0,68	0,58	0,36	-	-	-	-	-	-	
1	0,61	0,48	-	-	-	-	-	-	-	
2	10	1,00	0,98	0,97	0,94	0,92	0,89	0,85	0,80	0,79
	9,5	1,00	0,98	0,95	0,93	0,90	0,81	0,81	0,75	0,66
	9	0,99	0,97	0,94	0,91	0,87	0,83	0,77	0,69	0,65
	8,5	0,97	0,94	0,91	0,88	0,84	0,79	0,71	0,61	0,46
	8	0,94	0,92	0,89	0,85	0,80	0,74	0,65	0,51	0,32
	7,5	0,92	0,89	0,86	0,82	0,76	0,69	0,58	0,41	-
	7	0,89	0,87	0,83	0,78	0,72	0,63	0,49	0,27	-
	6,5	0,87	0,84	0,80	0,75	0,67	0,56	0,39	-	-
	6	0,85	0,81	0,77	0,71	0,62	0,48	0,27	-	-
	5,5	0,82	0,79	0,74	0,67	0,56	0,39	-	-	-
	5	0,80	0,76	0,70	0,62	0,48	0,27	-	-	-
	4	0,74	0,70	0,62	0,50	0,29	-	-	-	-
	3	0,69	0,62	0,51	0,32	-	-	-	-	-
2	0,62	0,55	0,38	0,25	-	-	-	-	-	
1	0,57	0,46	0,23	-	-	-	-	-	-	
4	10	1,00	0,99	0,98	0,97	0,95	0,93	0,90	0,85	0,79
	9,5	1,00	0,98	0,97	0,96	0,93	0,90	0,85	0,80	0,74
	9	1,00	0,98	0,96	0,94	0,91	0,87	0,82	0,77	0,70
	8,5	1,00	0,98	0,95	0,91	0,87	0,83	0,78	0,72	0,64
	8	0,98	0,95	0,92	0,89	0,84	0,80	0,74	0,67	0,57
	7,5	0,96	0,93	0,89	0,85	0,81	0,75	0,69	0,60	0,47
	7	0,94	0,90	0,86	0,82	0,77	0,71	0,63	0,52	0,28
	6,5	0,91	0,87	0,83	0,78	0,73	0,66	0,56	0,41	-
	6	0,88	0,84	0,80	0,75	0,68	0,60	0,48	0,26	-
	5,5	0,85	0,81	0,77	0,71	0,63	0,53	0,37	-	-
	5	0,83	0,78	0,73	0,66	0,57	0,45	0,21	-	-
	4	0,77	0,71	0,64	0,55	0,43	0,17	-	-	-
	3	0,70	0,63	0,55	0,42	0,18	-	-	-	-
2	0,64	0,55	0,43	0,22	-	-	-	-	-	
1	0,56	0,46	0,29	-	-	-	-	-	-	
7	10	1,00	0,98	0,96	0,87	0,91	0,88	0,85	0,81	0,77
	9,5	0,98	0,96	0,94	0,91	0,88	0,85	0,81	0,78	0,74
	9	0,97	0,94	0,91	0,89	0,85	0,82	0,79	0,75	0,70
	8,5	0,89	0,92	0,90	0,87	0,84	0,80	0,76	0,72	0,67
	8	0,94	0,91	0,88	0,85	0,82	0,79	0,73	0,68	0,63
	7,5	0,90	0,88	0,85	0,82	0,78	0,74	0,70	0,65	0,59
	7	0,87	0,85	0,82	0,79	0,75	0,71	0,66	0,60	0,54
	6,5	0,85	0,82	0,79	0,76	0,72	0,68	0,63	0,53	0,51
	6	0,82	0,79	0,76	0,73	0,69	0,65	0,60	0,54	0,47
	5,5	0,77	0,75	0,72	0,69	0,66	0,61	0,56	0,50	0,42
	5	0,74	0,72	0,69	0,66	0,62	0,58	0,52	0,45	0,37
	4	0,68	0,65	0,62	0,59	0,55	0,51	0,45	0,37	0,23
	3	0,61	0,58	0,55	0,51	0,47	0,42	0,34	0,19	-
2	0,54	0,51	0,47	0,43	0,38	0,32	0,22	-	-	
1	0,46	0,41	0,37	0,33	0,27	0,22	-	-	-	

Correction factors for Sensible cooling emission and Heating emission

Values in %

Model	Vdc	Available pressure (Pa)								
		0	10	20	30	40	50	60	70	80
1	10	1,00	0,98	0,96	0,93	0,91	0,87	0,83	0,79	0,74
	9,5	1,00	0,98	0,96	0,93	0,90	0,87	0,83	0,78	0,70
	9	1,00	0,98	0,96	0,93	0,90	0,87	0,82	0,75	0,61
	8,5	1,00	0,98	0,96	0,93	0,90	0,85	0,79	0,68	0,43
	8	1,00	0,98	0,96	0,93	0,89	0,84	0,74	0,51	-
	7,5	1,00	0,98	0,95	0,91	0,85	0,78	0,62	0,37	-
	7	1,00	0,97	0,87	0,88	0,80	0,69	0,49	-	-
	6,5	1,00	0,94	0,90	0,83	0,74	0,60	0,34	-	-
	6	0,95	0,91	0,85	0,78	0,67	0,48	-	-	-
	5,5	0,92	0,87	0,81	0,72	0,59	0,33	-	-	-
	5	0,89	0,83	0,76	0,66	0,49	-	-	-	-
	4	0,81	0,75	0,65	0,50	0,15	-	-	-	-
	3	0,74	0,65	0,52	0,19	-	-	-	-	-
2	0,65	0,55	0,33	-	-	-	-	-	-	
1	0,58	0,45	-	-	-	-	-	-	-	
2	10	1,00	0,98	0,96	0,93	0,90	0,87	0,83	0,77	0,76
	9,5	1,00	0,97	0,95	0,92	0,88	0,78	0,79	0,72	0,62
	9	0,99	0,96	0,93	0,89	0,85	0,80	0,73	0,65	0,61
	8,5	0,96	0,93	0,90	0,86	0,82	0,76	0,68	0,57	0,42
	8	0,93	0,90	0,87	0,83	0,78	0,70	0,61	0,47	0,28
	7,5	0,91	0,87	0,84	0,79	0,73	0,65	0,54	0,37	-
	7	0,88	0,84	0,80	0,75	0,69	0,59	0,45	0,24	-
	6,5	0,85	0,81	0,77	0,71	0,64	0,52	0,36	-	-
	6	0,82	0,79	0,74	0,67	0,58	0,44	0,24	-	-
	5,5	0,80	0,76	0,70	0,63	0,52	0,35	-	-	-
	5	0,77	0,73	0,67	0,58	0,44	0,24	-	-	-
	4	0,71	0,66	0,58	0,46	0,26	-	-	-	-
	3	0,65	0,58	0,47	0,29	-	-	-	-	-
2	0,58	0,50	0,34	0,22	-	-	-	-	-	
1	0,53	0,42	0,20	-	-	-	-	-	-	
4	10	1,00	0,99	0,98	0,96	0,94	0,92	0,88	0,83	0,76
	9,5	1,00	0,98	0,97	0,95	0,92	0,89	0,83	0,78	0,71
	9	1,00	0,98	0,96	0,93	0,89	0,85	0,79	0,74	0,67
	8,5	1,00	0,97	0,94	0,90	0,86	0,81	0,75	0,69	0,61
	8	0,98	0,95	0,91	0,87	0,82	0,77	0,71	0,63	0,53
	7,5	0,96	0,92	0,88	0,83	0,78	0,72	0,66	0,56	0,43
	7	0,93	0,89	0,84	0,79	0,74	0,68	0,59	0,48	0,25
	6,5	0,89	0,85	0,81	0,75	0,69	0,62	0,52	0,37	-
	6	0,87	0,82	0,77	0,72	0,65	0,56	0,44	0,23	-
	5,5	0,83	0,79	0,74	0,67	0,59	0,49	0,33	-	-
	5	0,81	0,75	0,69	0,62	0,54	0,41	0,19	-	-
	4	0,74	0,69	0,61	0,51	0,39	0,15	-	-	-
	3	0,66	0,59	0,51	0,38	0,16	-	-	-	-
2	0,60	0,51	0,40	0,19	-	-	-	-	-	
1	0,52	0,42	0,26	-	-	-	-	-	-	
7	10	1,00	0,97	0,95	0,85	0,89	0,85	0,82	0,78	0,74
	9,5	0,98	0,95	0,92	0,89	0,86	0,83	0,79	0,75	0,71
	9	0,95	0,93	0,90	0,86	0,83	0,79	0,76	0,71	0,67
	8,5	0,87	0,91	0,88	0,85	0,81	0,77	0,73	0,69	0,63
	8	0,92	0,89	0,86	0,83	0,79	0,76	0,70	0,65	0,59
	7,5	0,89	0,86	0,83	0,79	0,75	0,71	0,66	0,61	0,55
	7	0,85	0,82	0,79	0,76	0,72	0,67	0,63	0,57	0,50
	6,5	0,82	0,79	0,76	0,73	0,69	0,64	0,59	0,49	0,47
	6	0,79	0,76	0,73	0,70	0,66	0,61	0,56	0,50	0,43
	5,5	0,74	0,72	0,69	0,66	0,62	0,58	0,52	0,46	0,38
	5	0,71	0,69	0,66	0,63	0,59	0,54	0,49	0,42	0,34
	4	0,64	0,61	0,58	0,55	0,51	0,47	0,41	0,33	0,20
	3	0,57	0,54	0,51	0,48	0,43	0,38	0,30	0,16	-
2	0,50	0,47	0,43	0,40	0,35	0,28	0,19	-	-	
1	0,43	0,38	0,33	0,29	0,24	0,19	-	-	-	

WATER SIDE PRESSURE DROPS

Main coil

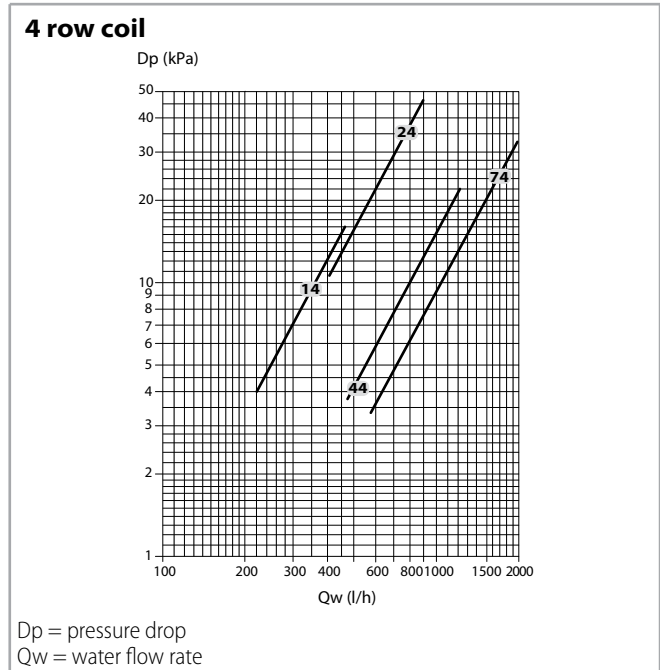
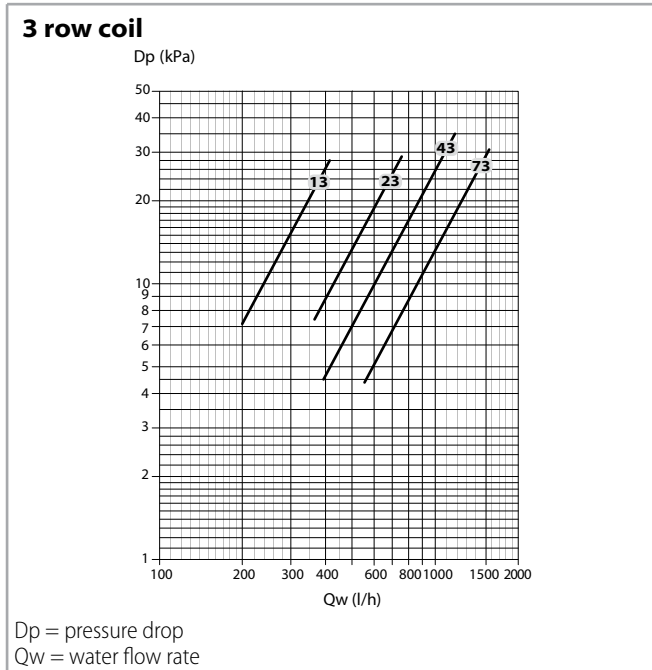

Pressure drop for mean water temperature of 10 °C, for different temperatures multiply the pressure drop figure by the K correction factors in the table.

	Mean water temperature (°C)						
	20	30	40	50	60	70	80
K correction factor	0,94	0,90	0,86	0,82	0,78	0,74	0,70

Additional coil

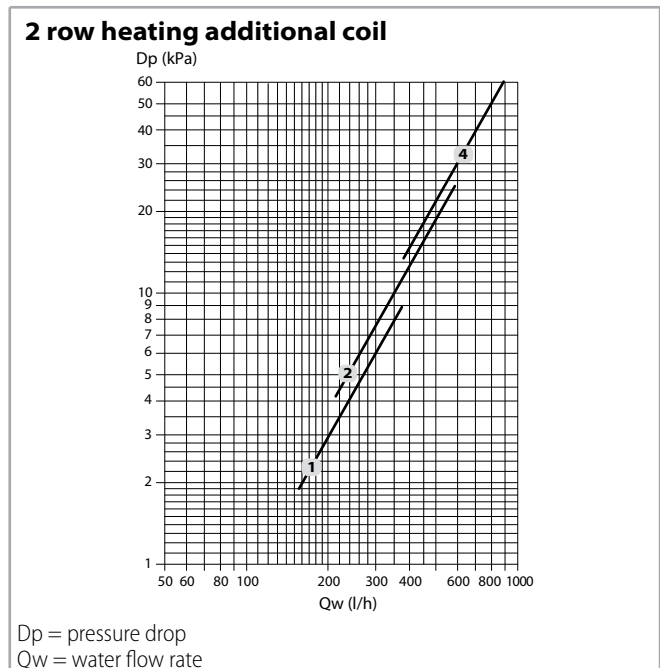
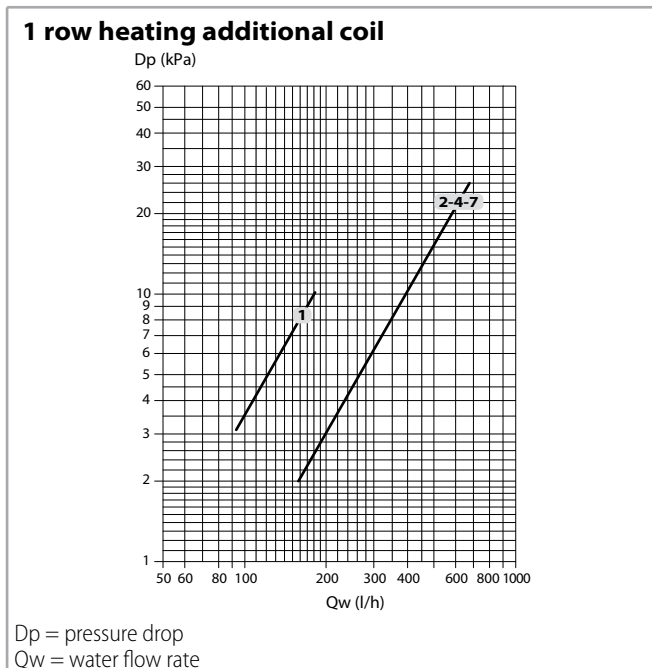

Pressure drop for mean water temperature of 60 °C, for different temperatures multiply the pressure drop figure by the K correction factors in the table.

	Mean water temperature (°C)			
	40	50	70	80
K correction factor	1,12	1,06	0,94	0,88

OPERATING LIMITS

Description		UoM	Value
Water flow	Max. water pressure drop	bars	10
	MIN. entering water temperature	°C	+5
	MAX. entering water temperature	°C	+85
Power supply	Single-phase rated operating voltage	V/Hz	230/50

Electric heater operation limits

Description		UoM	Value
Ambient air	Maximum temperature ⁽¹⁾	°C	+25
Power supply	Single-phase rated operating voltage	Vac/Ph/Hz	230/1/50

⁽¹⁾ with heating coil

Coils water flow limits

3 row coil

Model		CRSL-ECM 13	CRSL-ECM 23	CRSL-ECM 43	CRSL-ECM 73
Water flow rate Min.	l/h	100	150	200	300
Water flow rate Max.	l/h	750	1000	2000	3000

4 row coil

Model		CRSL-ECM 14	CRSL-ECM 24	CRSL-ECM 44	CRSL-ECM 74
Water flow rate Min.	l/h	150		300	400
Water flow rate Max.	l/h	1000	1500	2250	3300

1 row heating additional coil

Model		CRSL-ECM 13+1	CRSL-ECM 23+1	CRSL-ECM 43+1	CRSL-ECM 73+1
Water flow rate Min.	l/h	50	100		
Water flow rate Max.	l/h	350	500	750	

Model		CRSL-ECM 14+1	CRSL-ECM 24+1	CRSL-ECM 44+1	CRSL-ECM 74+1
Water flow rate Min.	l/h	50	100		
Water flow rate Max.	l/h	350	500	750	

2 row heating additional coil

Model		CRSL-ECM 13+2	CRSL-ECM 23+2	CRSL-ECM 43+2
Water flow rate Min.	l/h	100		
Water flow rate Max.	l/h	350	500	750

Motor electrical data - max. absorption

Model		CRSL-ECM 1	CRSL-ECM 2	CRSL-ECM 4	CRSL-ECM 7
Motor absorption	W	52	134	131	303
Current absorbed	A	0,4	1,1		1,4

DIMENSION, WEIGHT AND WATER CONTENT

Dimensions

Vertical installation

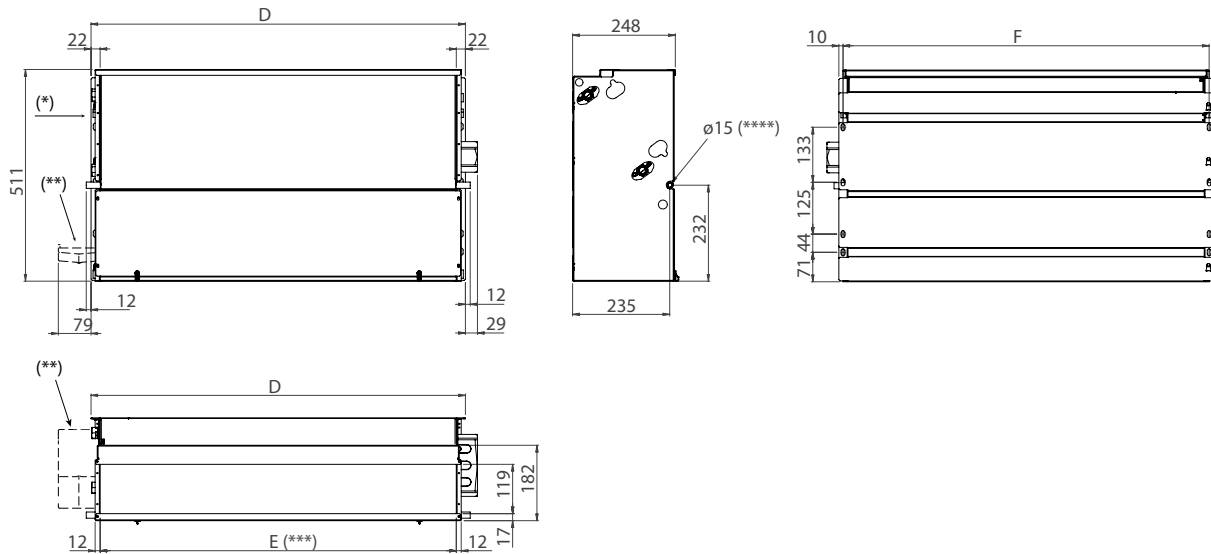

- (*) = Coil connections on the left
- (**) = Auxiliary condensate tray (optional)
- (***) = Supply frame dimension E x 119 mm
- (****) = External diameter

Horizontal installation

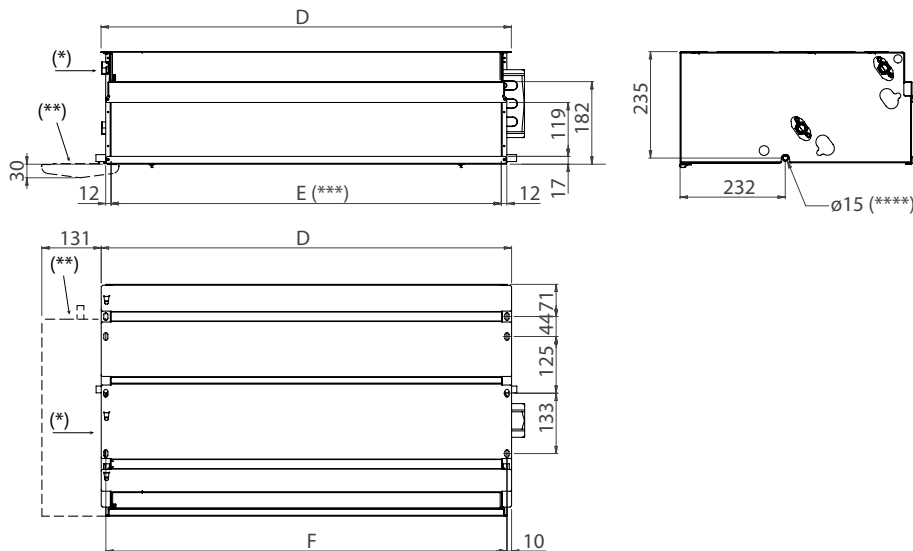

- (*) = Coil connections on the left
- (**) = Auxiliary condensate tray (optional)
- (***) = Supply frame dimension E x 119 mm
- (****) = External diameter

Model		CRSL-ECM 1	CRSL-ECM 2	CRSL-ECM 4	CRSL-ECM 7
D	mm	689	904	1119	1549
E	mm	645	860	1075	1505
F	mm	669	884	1099	1529

Coil connections

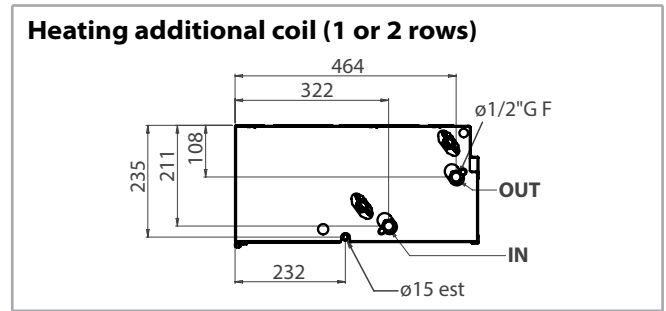
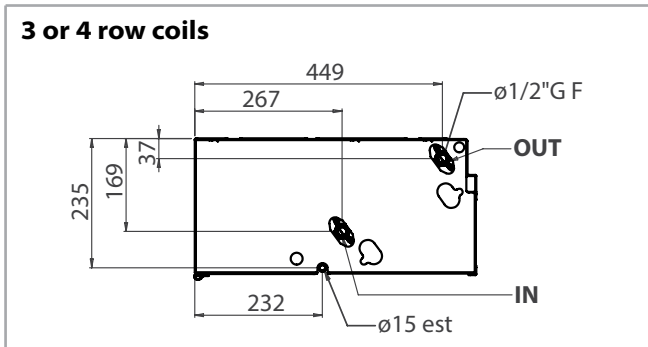

Packed unit

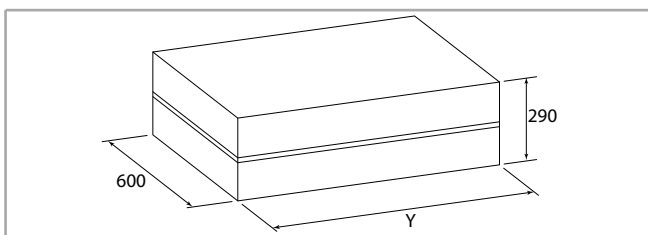

Model		CRSL-ECM 1	CRSL-ECM 2	CRSL-ECM 4	CRSL-ECM 7
Y	mm	820	1035	1250	1790

Weight

Weights with packaging

Model		CRSL-ECM 1	CRSL-ECM 2	CRSL-ECM 4	CRSL-ECM 7
3 rows	kg	18,9	25,6	29,4	49,9
3+1 rows	kg	20,1	27,1	31,2	52,2
3+2 rows	kg	20,8	28,0	32,3	-
4 rows	kg	19,9	26,9	30,5	51,6
4+1 rows	kg	21,1	28,4	32,3	53,9

Weights without packaging

Model		CRSL-ECM 1	CRSL-ECM 2	CRSL-ECM 4	CRSL-ECM 7
3 rows	kg	17,9	24,6	26,4	44,9
3+1 rows	kg	19,1	26,1	28,2	47,2
3+2 rows	kg	19,8	27,0	29,3	-
4 rows	kg	18,9	25,9	27,5	46,6
4+1 rows	kg	20,1	27,4	29,3	48,9

Water content

Model		CRSL-ECM 1	CRSL-ECM 2	CRSL-ECM 4	CRSL-ECM 7
3 rows	l	0,9	1,6	1,9	3,2
4 rows	l	1,3	2,2	2,8	4,2
+1 row	l	0,3	0,5	0,6	0,9
+2 rows	l	0,6	1,0	1,2	-

WALL ELECTRONIC CONTROLS

All the units of the Carisma CRSL-ECM range can be supplied with a wide range of controls that allows managing one single unit or several units (with the use of the power units).

The room temperature can be controlled through electronic room thermostats, with different solutions according to every ambient conditions.

The WM-AU, T-MB and WM-S-ECM electronic thermostats control the room temperature precisely and are suitable when the user wants to set the fan speed.

Note: all the controls are described in detail in the "Fan Coil Control Range literature".

Controls

WM-AU control (*)



230V 50-60Hz

T-MB control (*)



230V 50-60Hz

WM-S-ECM control



230V 50Hz

(*) To be used with UPM-AU or UP-AU only

CONTROLS FOR MB VERSION

All the units Carisma CRSL can be supplied in a wide range of controls, which allow managing one single unit or several units by using the Modbus RTU - RS 485. Units can be managed according to the Master/Slave logic (up to 20 units) or by supervisory components. The system consists in a MB board and a series of controls, such as the T-MB wall control, the

RT03 infra-red remote control, the PSM-DI multifunction control, the Sabianet supervisory program, the T-DI Touch screen multifunction control panel and the Web Gateway for Sabiana Cloud SabWeb.

Note: all the controls are described in detail in the "Fan Coil Control Range literature".

Controls

MB electronic board

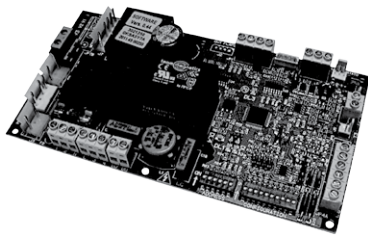

T-MB control



RT03 remote control



PC and Sabianet screenshot

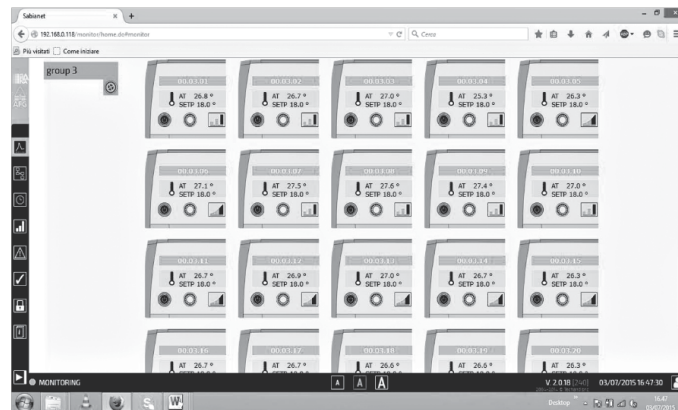

T-DI Touch screen multifunction control panel

The T-DI multifunction control panel lets supervise and control more units with MB or SIOS boards; the panel is equipped with a 7 inches touch screen display and a serie of graphical pages that allows an easy reading of the data sent by the fan coils and the management of up to 60 units (max. 60 units: SIOS + MB).
 With the T-DI multifunction control panel it is also possible to control the units remotely with the specific Sabiana Cloud App for Android and iOS.
 The Sabiana Cloud application is simple to use and lets have complete control of all the connected units.

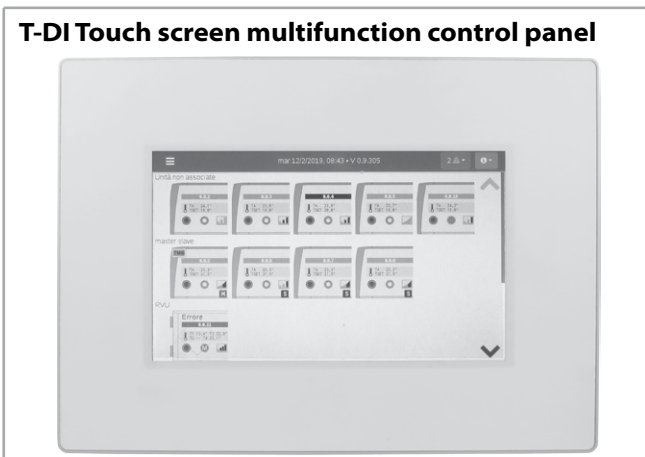

Web gateway for Sabiana Cloud

With the Web gateway for "Sabiana Cloud" it is possible to control remotely up to 60 units, equipped with MB or SIOS boards (max. 60 units: SIOS + MB), with the specific APP for Android and iOS.
 The "Sabiana Cloud" APP is simple to use and lets have complete control of all the connected units.



PSM-DI multifunction control panel

With the PSM-DI multifunction control panel it is possible to control remotely up to 60 units, equipped with MB or SIOS boards (max. 60 units: SIOS + MB).
 The PSM-DI multifunction control panel supervises via Bus network all the connected units.
 The remote connection (stand-alone) is not possible.



KNX BUS SYSTEM

The KNX bus system is a building automation standard for controlling, managing and monitoring a wide range of products for:

- Heating, cooling, ventilation.
- Lighting.
- Alarm systems.
- Audio and video systems.
- Electricity and gas.

Since 2016, Sabiana is a certified member of the KNX association and the certified products can be added to this system in compliance with the tests carried out at KNX laboratories.



KNX devices

The Sabiana WM-KNX room thermostat controls and adjusts the temperature of a room or area in a building. In combination with one or several UP-KNX power units, the thermostat is able to control the operation of terminal units such as fan coils. The appliance consists of an

LCD display with adjustable backlight and a sensor for measuring the room temperature.

WM-KNX is suitable for installation in a wall recessed box (to be used with UP-KNX and with PL mounting plate only).

Note: all the controls are described in detail in the "Fan Coil Control Range literature".

Recessed thermostat WM-KNX



Power unit UP-KNX



WM-KNX with rectangular plate



WM-KNX with square plate



ACCESSORIES

VBP main coil 3 way valve

Control valve kit: 3 way valve, ON-OFF 230 V, with electric motor and mounting kit with micrometric lockshield valve.

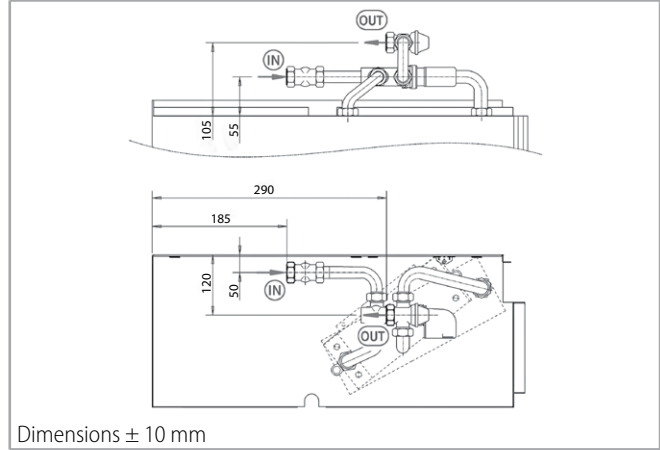
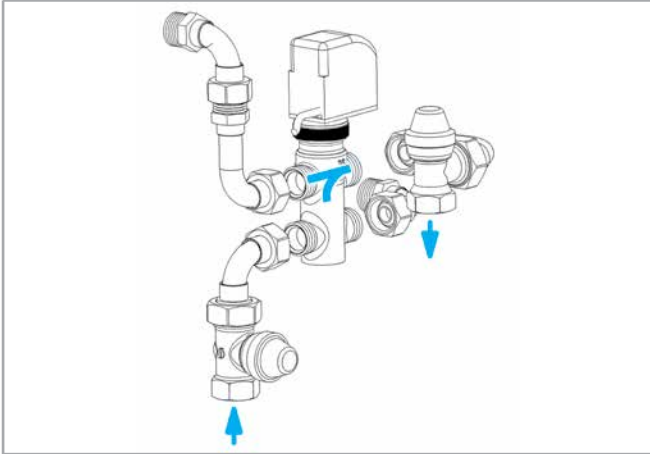

Model	Valve			Micrometric lockshield valve			FITTED		NOT FITTED	
	DN	(Ø)	Kvs	DN	(Ø)	Kvs	Code	Type	Code	Type
1	15	1/2"	1,6	15	1/2" F	2,0	9066561H	VBPM-C G1-5	9066560H	VBPS-C G1-5
2-3-4-5	20	3/4"	2,5	15	1/2" F	2,0	9060471H	VBPM-C G6-9	9060474H	VBPS-C G6-9
6-7	20	3/4"	4,0	20	3/4" F	3,5	9069208H	VBPM-C G8S	9069206H	VBPS-C G8S

Water side pressure drop (Kvs) diagrams to p. 60

VBA additional coil 3 way valve

Control valve kit: 3 way valve, ON-OFF 230 V, with electric motor and mounting kit with micrometric lockshield valve.

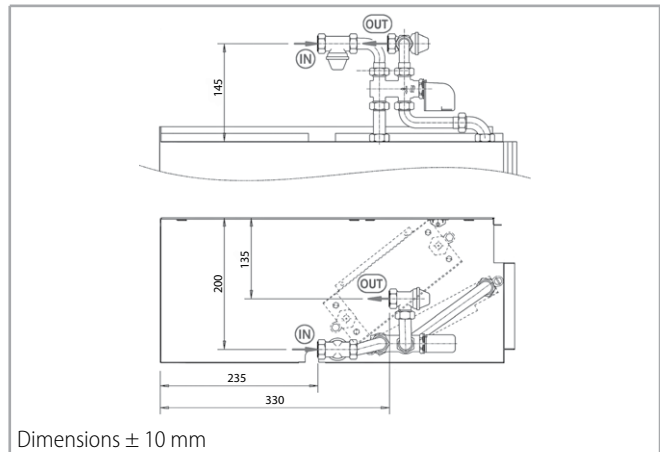
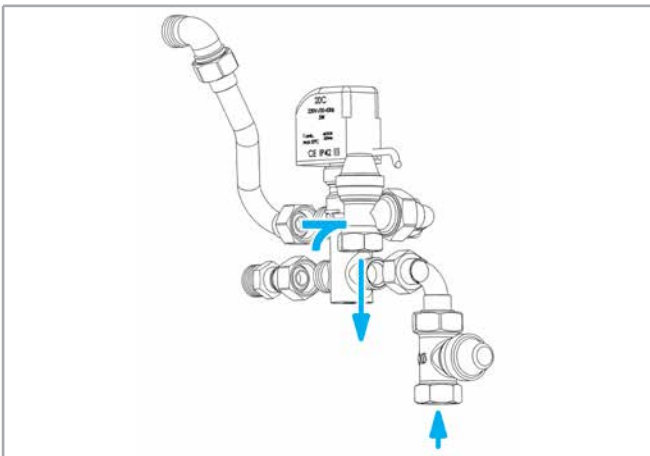

Model	Valve			Micrometric lockshield valve			FITTED		NOT FITTED	
	DN	(Ø)	Kvs	DN	(Ø)	Kvs	Code	Type	Code	Type
1 ÷ 7	15	1/2"	1,6	15	1/2" F	2	9060472H	VBAM-C G1-9	9060475H	VBAS-C G1-9

Water side pressure drop (Kvs) diagrams to p. 60

VS simplified kit for 3 way valve

3 way valve, ON-OFF 230 V with electric motor and mounting kit without micrometric lockshield valve. Valve with flat connection.

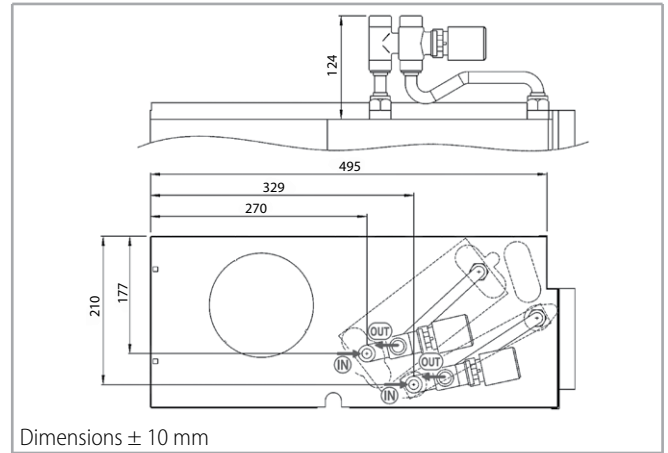
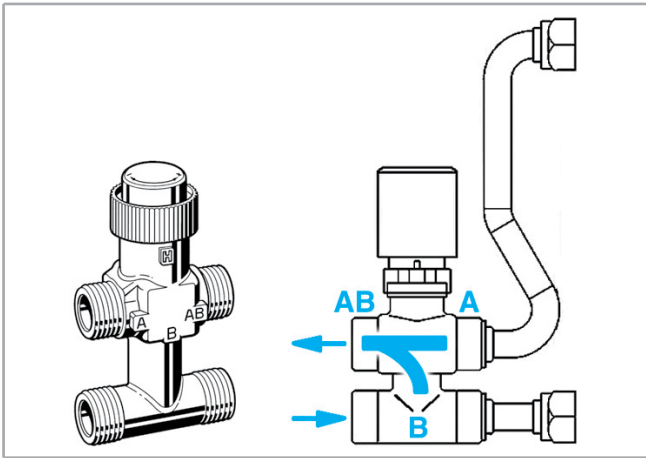

Dimensions ± 10 mm

Model	DN	(Ø)	Kvs	MAIN COIL			
				FITTED		NOT FITTED	
				Code	Type	Code	Type
1	15	1/2"	1,6	9066571H	VSPM-C G1-5	9066570H	VSPS-C G1-5
2-3-4-5	20	3/4"	2,5	9060484H	VSPM-C G6-9	9060481H	VSPS-C G6-9
6-7	20	3/4"	4,0	9069211H	VSPM-C G8S	9069210H	VSPS-C G8S
				ADDITIONAL COIL			
1 ÷ 7	15	1/2"	1,6	9060483H	VSAM-C G1-9	9060480H	VSAS-C G1-9

Water side pressure drop (Kvs) diagrams to p. 60

V2 2 way valve for main and additional coil

2 way valve ON-OFF 230 V

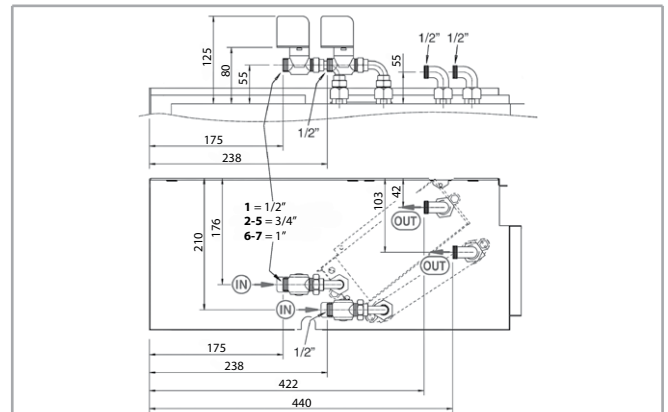
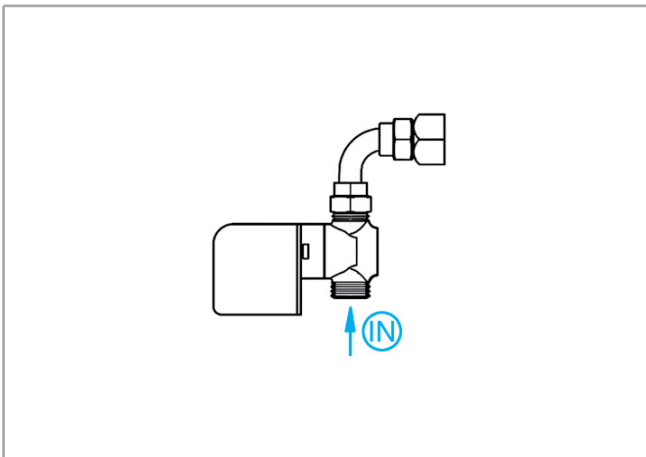

Dimensions ± 10 mm

Model	DN	(Ø)	Kvs	MAIN COIL			
				FITTED		NOT FITTED	
				Code	Type	Code	Type
1	15	1/2"	1,7	9066573H	V2M-C G1-5	9066575H	V2S-C G1-5
2-3-4-5	20	3/4"	2,8	9066574H	V2M-C G6-9	9066576H	V2S-C G6-9
6-7	25	1"	4,0	9069209H	V2M-C G8S	9069207H	V2S-C G8S
				ADDITIONAL COIL			
1 ÷ 7	15	1/2"	1,7	9066573H	V2M-C G1-5	9066575H	V2S-C G1-5

Water side pressure drop (Kvs) diagrams to p. 60

Water side pressure drop VBP - VBA

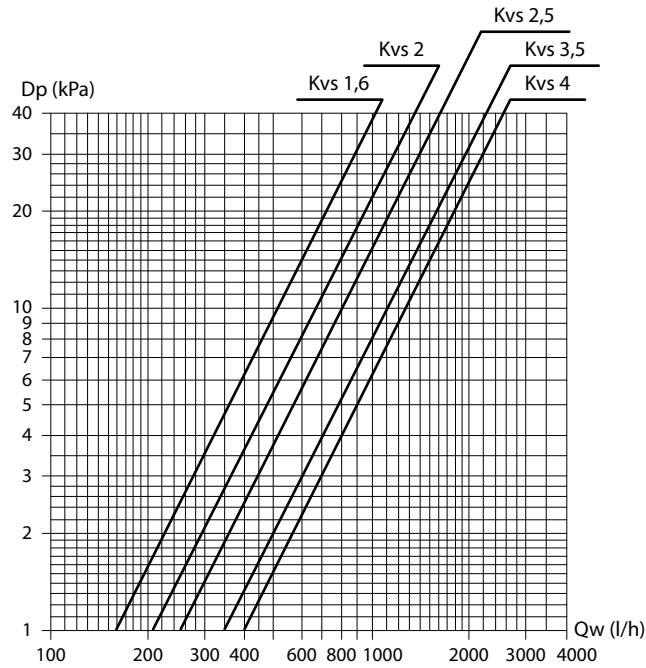

Dp = pressure drop
Qw = water flow rate

Water side pressure drop VS - V2

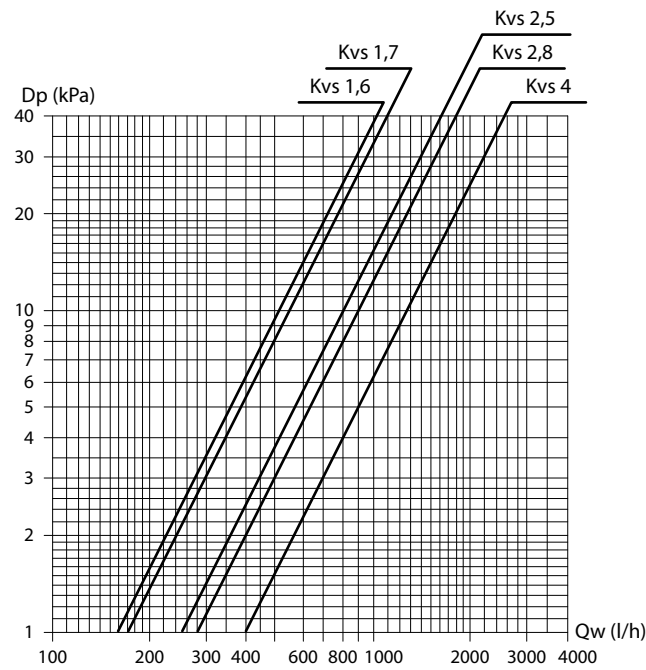

Dp = pressure drops
Qw = water flow rate

3 way double valve kit for 4 tube installation and single coil

The kit consists of:

- 2 special 3 way valves.
- 2 230 Volt ON-OFF actuators with internal safety micro switch.
- Insulated pipe kit.
- External valve insulation sleeve.

The kit uses a special 3 way valve which allows the transformation of the fan coil, equipped with one single coil, into a 4 tube installation.

The new 4X2 valve has been designed to keep the water flow between flow and return perfectly separated, allowing its use in parallel.

Therefore, it can be used on 4 pipe fan coil systems with one single heat-exchange coil on board the fan coil.

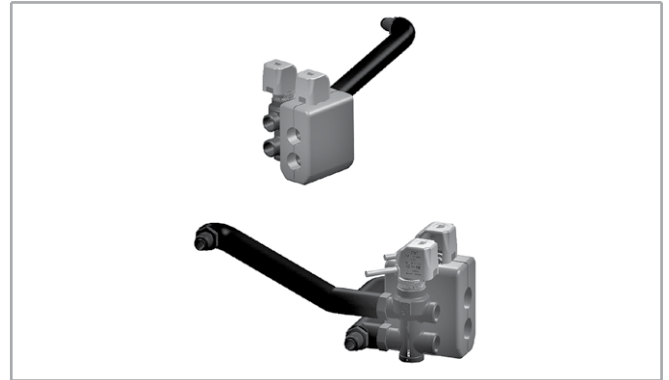
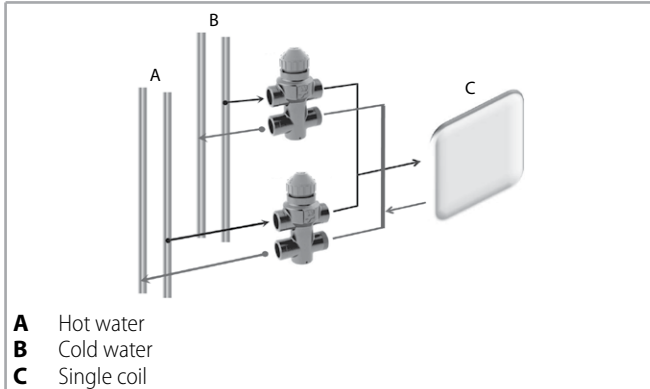

Model	Ø	Kvs	FITTED		NOT FITTED	
			Code	Type	Code	Type
1 ÷ 7	3/4"	2,2	9066572W	V3M4X2	9066562W	V3S4X2

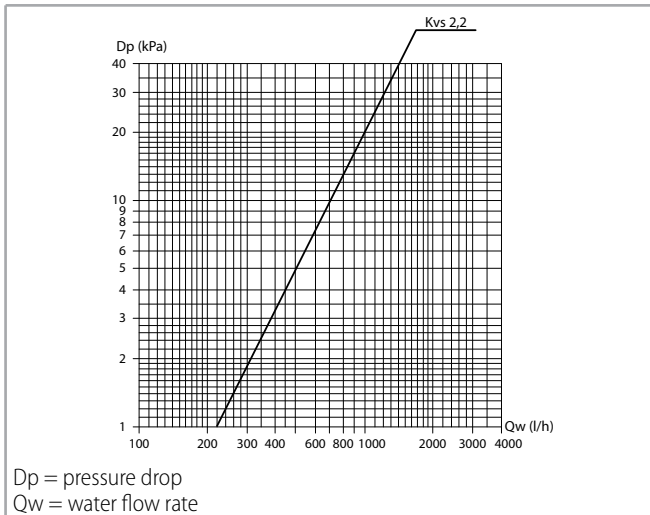

Double actuator electrical connections

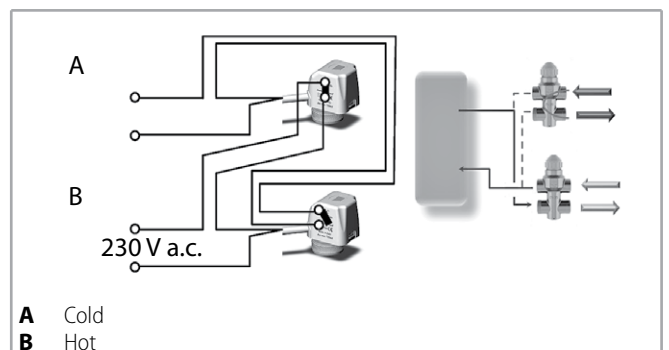
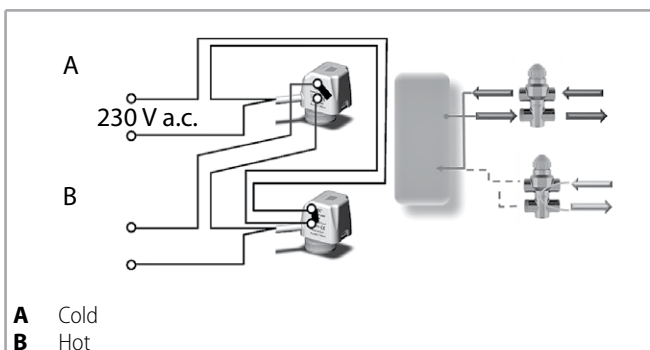

Balancing valves independent from the system pressure

- The balancing valve and a combined 2 way valve allow the regulation of the water flow value autonomously, regardless of the system pressure, and the control of the flow by using an ON/OFF electro-thermal actuator.
- The balancing valve allows you to balance the hydraulic system by supplying the required water flow, for each fan- coil, and to maintain it even under partial load conditions.
- A graduated ring nut placed under the valve allows you to set the flow rate value and also allows direct reading of the set value.



Valve operation logic

- "p1" the valve inlet pressure.
- "p3" the outlet pressure.
- "p2" the diaphragm activation pressure, which allows differential pressure "p2" – "p3" to be maintained at a constant value, in order to guarantee the water to flow at the set value.

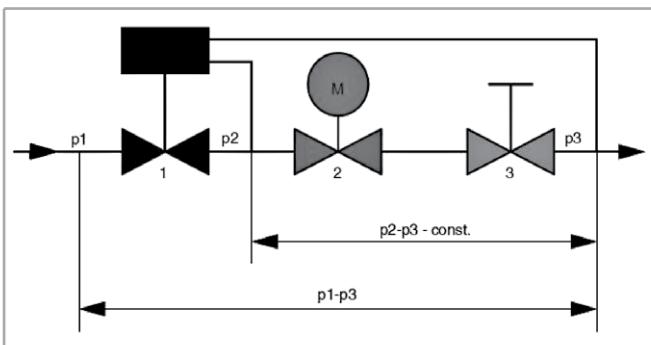

The minimum differential pressure "p1" – "p3", required to guarantee the correct value of the set water flow rate, is indicated in the diagrams on p. 63.

This is an essential factor to size the system pressure drop and pump pressure head.

The flow rate is kept at a constant value only if the valve pressure drop is higher than the indicated value.

Minimum operating differential pressure

The minimum differential pressure and the balancing valve pressure drop must be considered to size the system pumps.

The flow rate remains stable only if the water side pressure drop will be more than the one shown in the p. 63 diagrams.

The following diagram shows an example of the flow rate trend according to the pressure drop and calibration required.

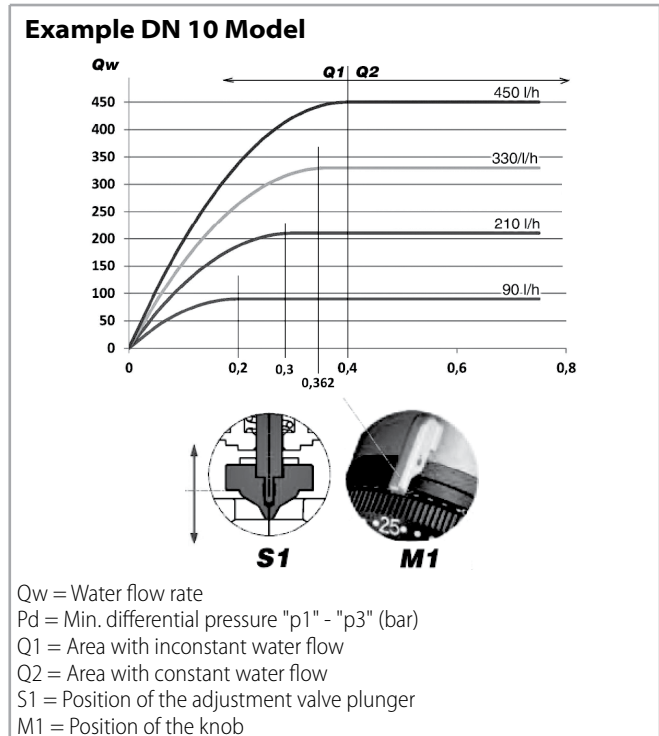

The valve upstream-downstream minimum differential pressure ("p1" – "p3"), which depends on the valve calibration value, must be exceeded to access the constant flow rate field.

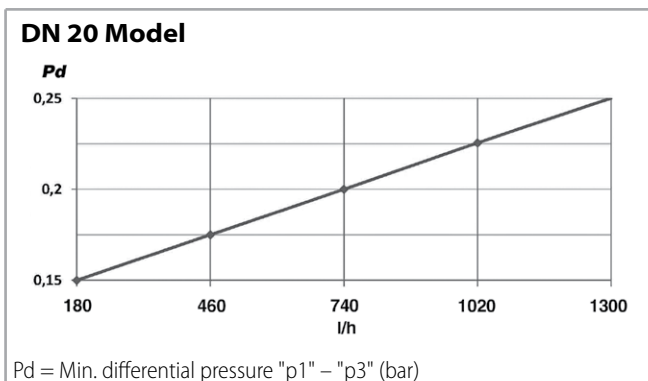
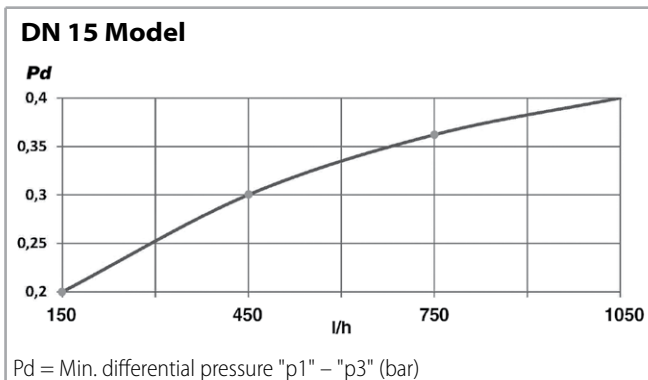
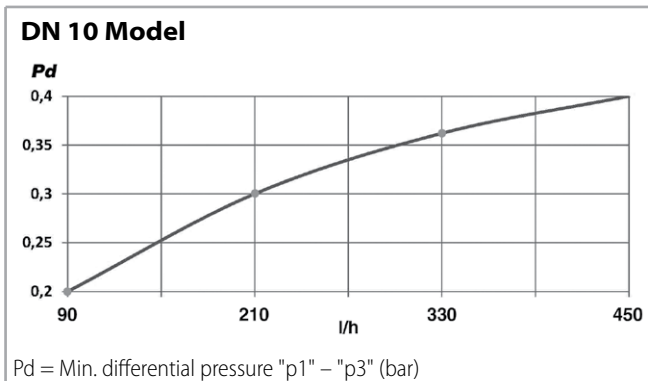

E.g., when sizing the system pump, in which the DN 10 valves will be installed and in which 210 l/h are constantly required for each device, consider a useful pressure of 0.3 bar (to compensate the pressure drop of the valve) for each balancing valve. Therefore, the pressure drop values produced by the system balancing valves must be summed and the pump must be sized to produce a pressure equal to or greater than the value obtained previously.

Benefits

- Reduced dimensions.
- Easy installation on 2 or 4 pipe devices.
- Pre-regulation of the nominal value set even with installed actuator.
- Easy display of the nominal value set. Nominal values are indicated in 10 l/h without any conversion.

- Guarantee of constant flow rate set even with partial loads.
- Pre-regulation can be blocked and leaded with the locking ring.

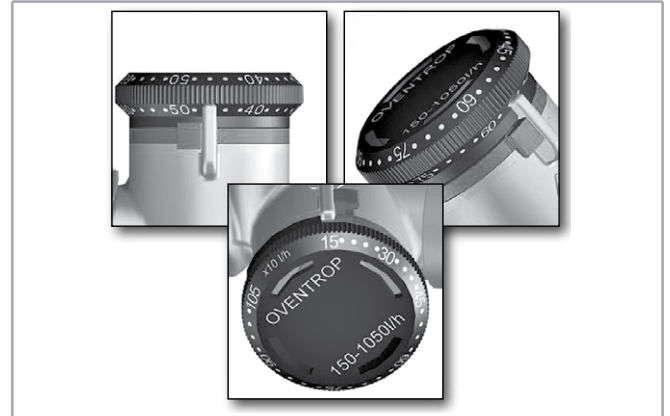

Technical specifications

DN model	Flow rate range (l/h)	Kvs
DN 10	90 - 450	1,1
DN 15	150 - 1050	1,8
DN 20	180 - 1300	2,5

Operation limits of the balancing valves

- Maximum operating temperature: 120°C
- Maximum operating pressure: 16 bar
- Maximum % of water/glycol mixture: 50%
- Minimum operating temperature: -10°C
- Maximum differential pressure: 4 bar

Balancing valves for main coil

2 way valve for main coil and assembly kit.

The valve is supplied equipped with 230 Volt electro-thermal actuator for the ON/OFF control.

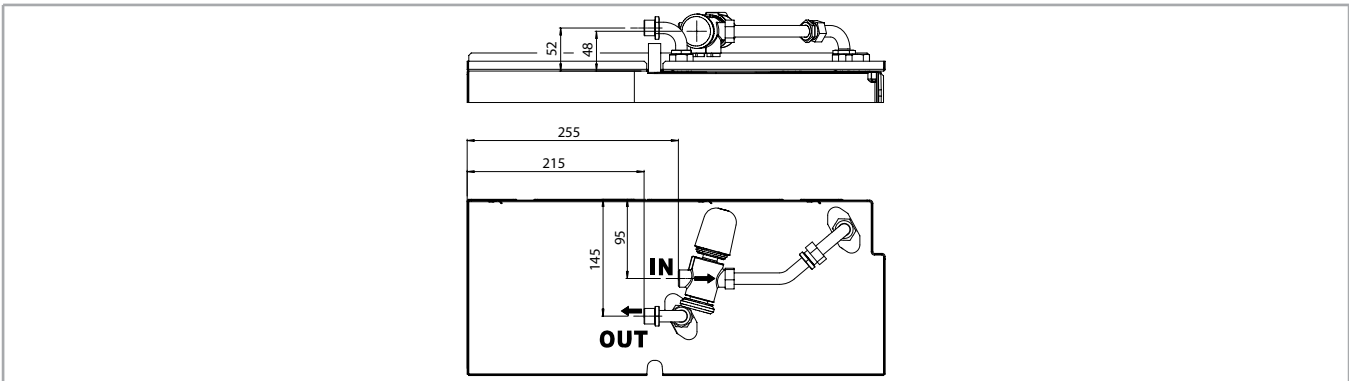

Model	DN	(Ø)	Qwr	FITTED		NOT FITTED	
				Code	Type	Code	Type
1	10	1/2"	90-450	9066660	V20VBPM 90-450	9066650	V20VBPS 90-450
2-3-4	15	3/4"	150-1050	9066661	V20VBPM 150-1050	9066651	V20VBPS 150-1050
5-6-7	20	1"	180-1300	9066662	V20VBPM 180-1300	9066652	V20VBPS 180-1300

Balancing valves for additional coil

2 way valve for additional coil and assembly kit.

The valve is supplied equipped with 230 Volt electro-thermal actuator for the ON/OFF control.

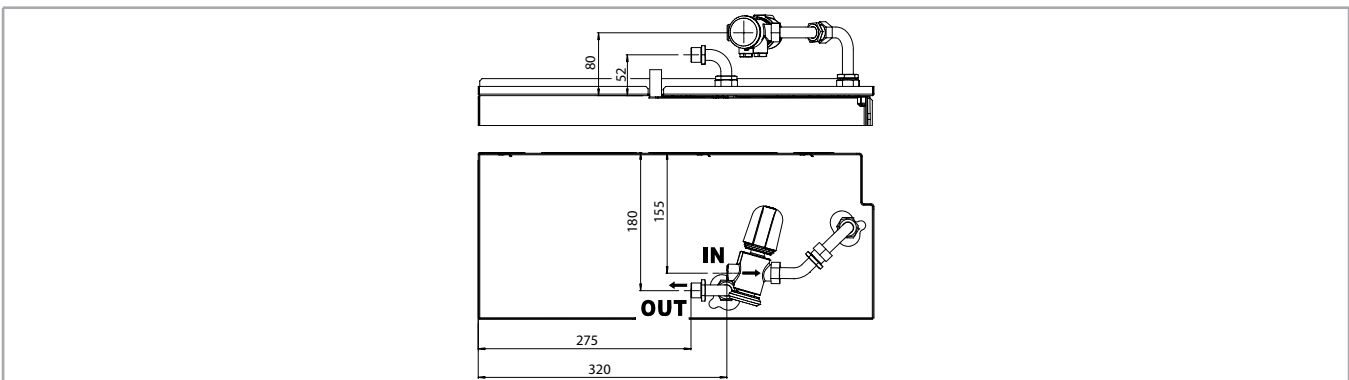

Model	DN	(Ø)	Qwr	FITTED		NOT FITTED	
				Code	Type	Code	Type
1-2-3-4	10	1/2"	90-450	9066663	V20VBAM 90-450	9066653	V20VBAS 90-450
5-6-7	15	3/4"	150-1050	9066664	V20VBAM 150-1050	9066654	V20VBAS 150-1050

2 pipe unit

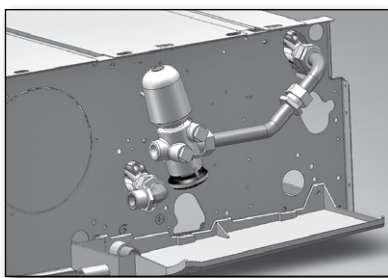

4 pipe unit

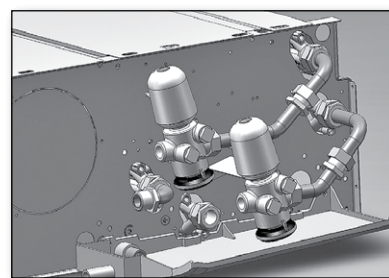

BSV extension condensate collection tray to cover valve assembly

(for vertical units)

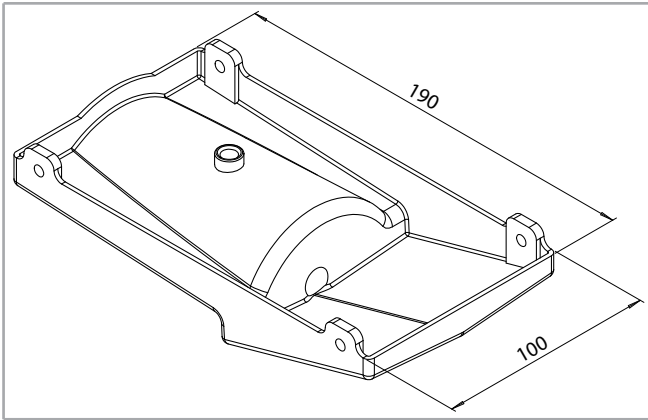

Model	Type	Code
1 ÷ 7	BSV-C	6060400

BSI-C extension condensate collection tray to cover valve assembly

(for horizontal units)

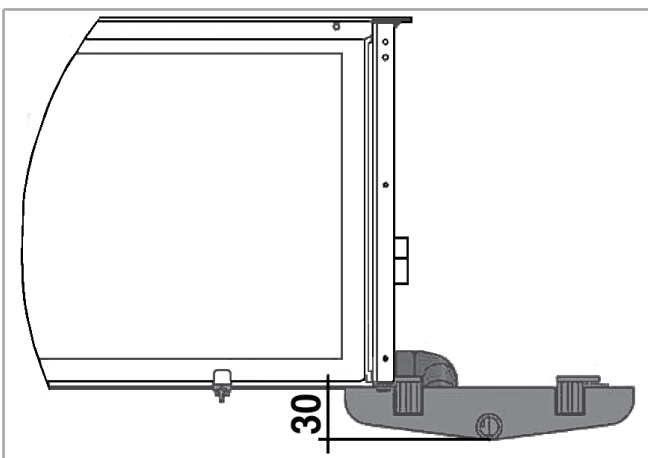
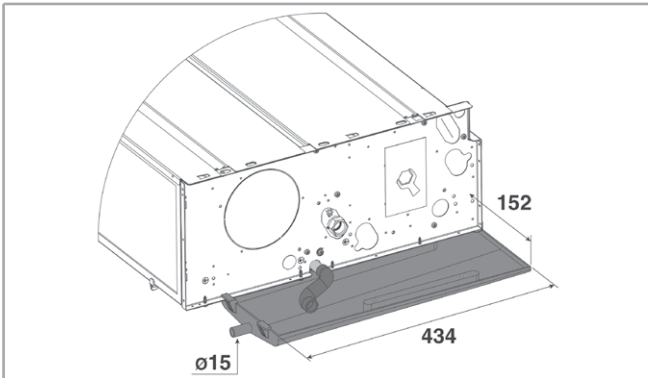

Model	Type	Code
1 ÷ 7	BSI-C	6066039

DRPV-C condensate pump

(for vertical units)

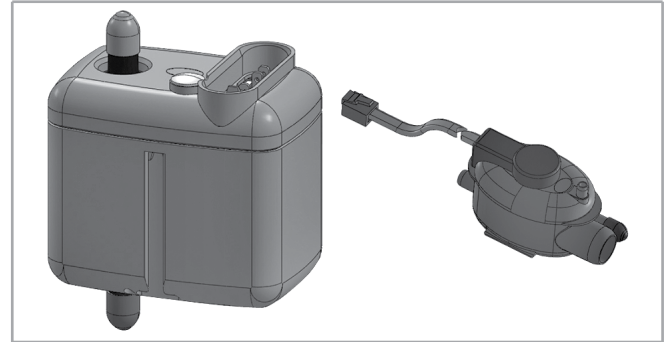

Model	FITTED		NOT FITTED	
	Type	Code	Type	Code
1 ÷ 7	DRPV-C-M	9066297	DRPV-C-S	9066296

Height for vertical flow (m)	Water flow (l/h) depending on the length of horizontal flow	
	5 m	10 m
1	7,6	7,2
2	5,6	5,2
3	4,0	3,7
4	3,2	2,9

DRPI-C fitted condensate pump

(for horizontal units)

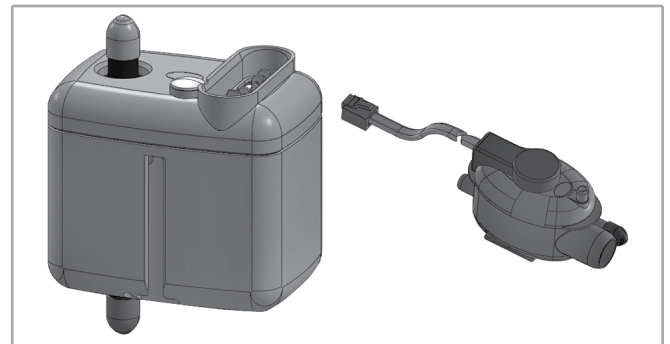

Model	NOT FITTED	
	Type	Code
1 ÷ 7	DRPI-C	9066180

Height for vertical flow (m)	Water flow (l/h) depending on the length of horizontal flow	
	5 m	10 m
1	7,6	7,2
2	5,6	5,2
3	4,0	3,7
4	3,2	2,9

SCR plastic condensate drain pipe with fast connection

(allows correct condensate drain)

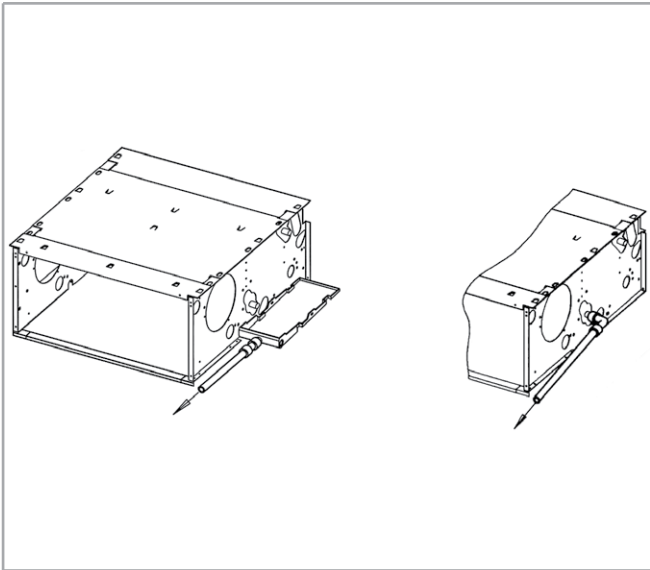

Model	Type	Code
1 ÷ 7	SCR-C	6060420

KAF frontal intake kit

Bottom closing panel and filter sliding guides.

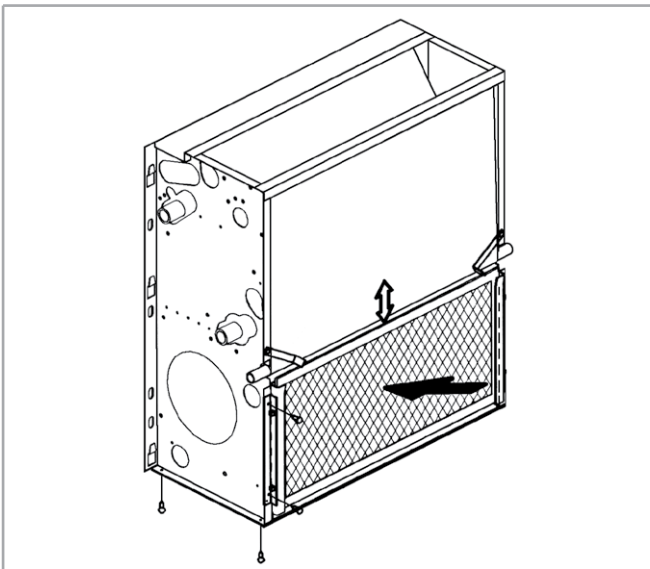

Model	FITTED	
	Type	Code
1	KAF-S SL1	9069361
2	KAF-S G2	9069072
3 - 4	KAF-S G3	9069073
5	KAF-S SL5	9069365
6 - 7	KAF-S SL6-7	9069366

BEL electric heater

1 PHASE 230 V.

Electric heater with integral: safety thermostat and relay control.

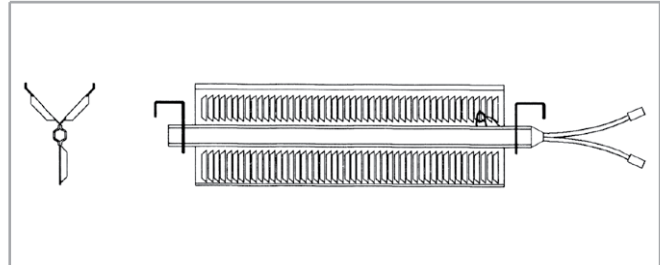

Model	Type	Watt (W)	Code
1	BEL-I G3-4 /15	1500	9066613
	BEL-I G3-4 /09	900	9066603
	BEL-I G3-4 /06	600	9066593
2	BEL-I G5-6 /20	2000	9066615
	BEL-I G5-6 /12	1250	9066605
	BEL-I G5-6 /07	750	9066595
3 - 4	BEL-I G7-9 /25	2500	9066617
	BEL-I G7-9 /15	1500	9066607
	BEL-I G7-9 /10	1000	9066597
5	BEL-I SL5 /27	2750	9038037
	BEL-I SL5 /16	1650	9038038
	BEL-I SL5 /11	1100	9038039
6 - 7	BEL-I SL6-7 /35	3500	9038047

GRAG air inlet grid

To be used with FRD straight inlet flange.

Made of anodized aluminium.

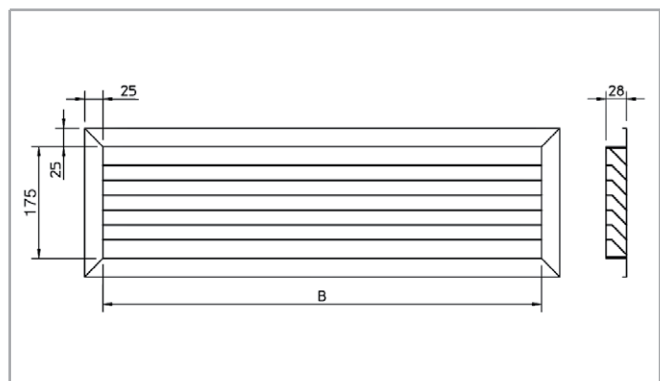

Model	Type	B mm	Code
1	GRAG-C 3-4	575	9060765
2	GRAG-C 5-6	775	9060766
3 - 4	GRAG-C 7-9	975	9060767
5	GRAG-C SL5	1175	9069145
6 - 7	GRAG-C S4	1425	9038042

FRD straight inlet flange

Can be used together with GRAG air inlet grid.
Made of galvanized steel.

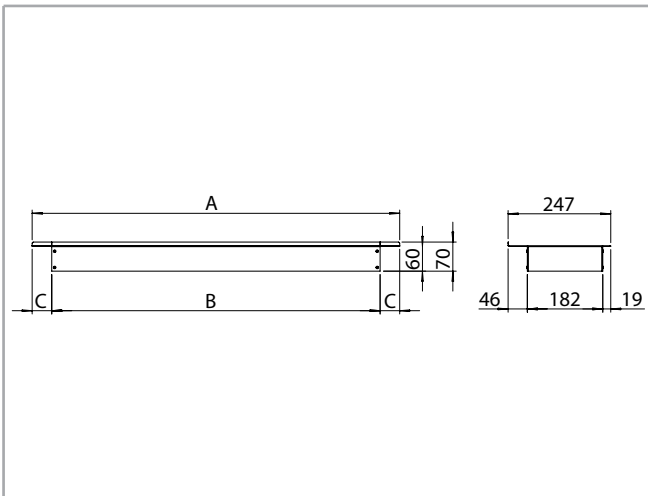

Model	Type	A mm	B mm	C mm	Code
1	FRD-C SL1	669	589	40	9069371
2	FRD-C 4S	884	790	47	9038002
3 - 4	FRD-C 8-9	1099	989	55	9060724
5	FRD-C SL5	1314	1190	62	9069375
6 - 7	FRD-C SL6-7	1529	1439	45	9069376

GRAP air inlet grid

To be used with FR 90 90° inlet flange.
Made of anodized aluminium.

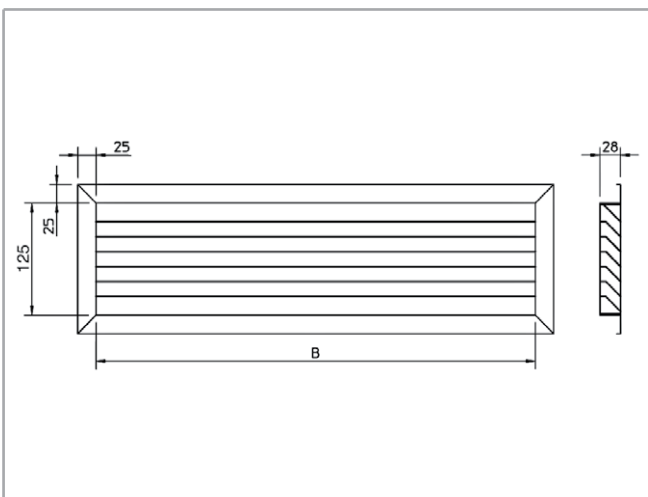

Model	Type	B mm	Code
1	GRAP-C 3-4	575	9060761
2	GRAP-C 5-6	775	9060762
3 - 4	GRAP-C 7-9	975	9060763
5	GRAP-C SL5	1175	9069155
6 - 7	GRAP-C S4	1425	9038041

FR 90 90° inlet flange

Can be used together with GRAP air inlet grid.
Made of galvanized steel.

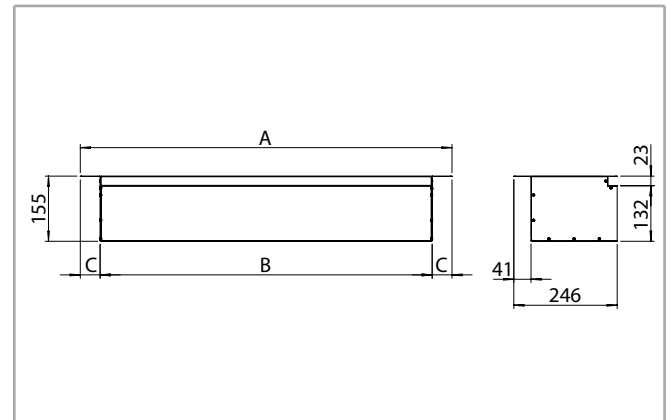

Model	Type	A mm	B mm	C mm	Code
1	FR90-C SL1	669	589	40	9069381
2	FR90-C 4S	884	790	47	9038001
3 - 4	FR90-C 8-9	1099	989	55	9060714
5	FR90-C SL5	1314	1190	62	9069385
6 - 7	FR90-C SL6-7	1529	1439	45	9069386

PRC air inlet spigot plenum

Made of galvanized steel insulated with polyethylene lining.

All the plenums are supplied with spigots for the connection of flexible ducts.

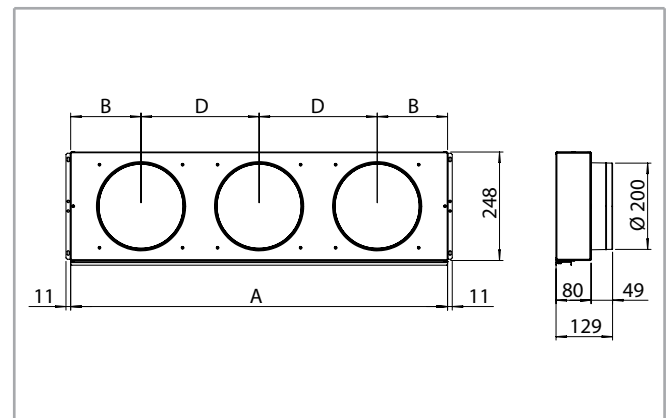

Model	Type	A mm	B mm	D mm	Spigots n°	Code
1	PRC-C SL1	647	167	313	2	9069181
2	PRC-C 4S	862	161	270	3	9038050
3 - 4	PRC-C 8-9	1077	190	348	3	9066468
5	PRC-C SL5	1292	223	354	4	9069185
6 - 7	PRC-C SL6-7	1507	223	354	4	9069186

FMD straight outlet flange

Made of galvanized steel.

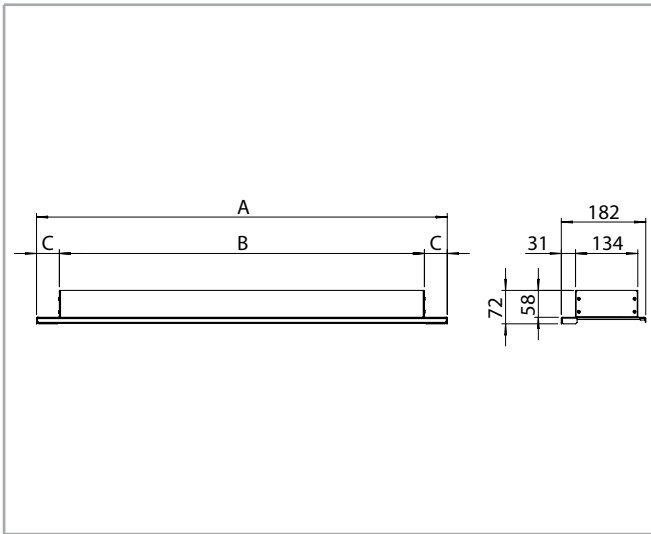

Model	Type	A mm	B mm	C mm	Code
1	FMD-CSL1	673	589	42	9069391
2	FMD-C4S	888	790	49	9069232
3-4	FMD-C8-9	1103	989	57	9066378
5	FMD-CSL5	1318	1190	64	9069395
6-7	FMD-CSL6-7	1533	1439	47	9069396

FM 90 90° outlet flange

Made of galvanized steel insulated with polyethylene lining.

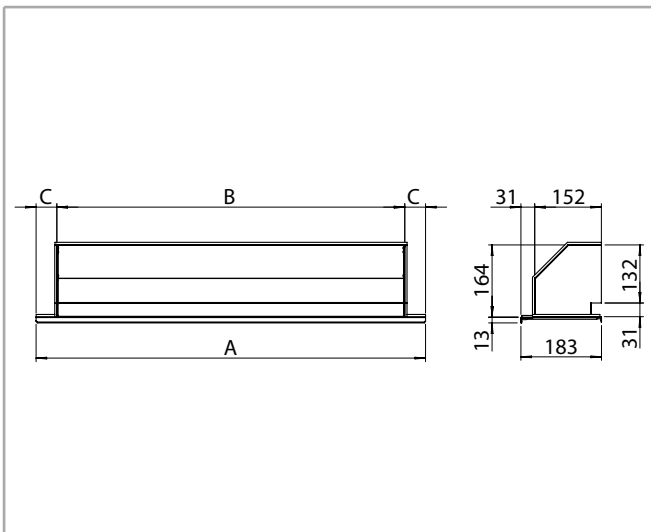

Model	Type	A mm	B mm	C mm	Code
1	FM90-CSL1	669	589	40	9069401
2	FM90-CS4	884	790	47	9069242
3-4	FM90-C8-9	1099	989	55	9066388
5	FM90-CSL5	1314	1190	62	9069405
6-7	FM90-CSL6-7	1529	1439	45	9069406

PMC spigot diffuser

Made of galvanized steel insulated with polyethylene lining.

All the plenums are supplied with spigots for the connection of flexible ducts.

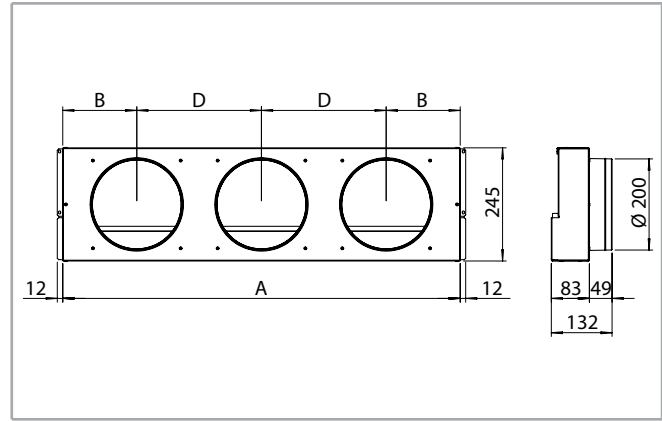

Model	Type	A mm	B mm	D mm	Spigots n°	Code
1	PMC-CSL1	645	166	313	2	9069191
2	PMC-C4S	860	160	270	3	9069222
3-4	PMC-C8-9	1075	189	348	3	9066368
5	PMC-CSL5	1290	180	310	4	9069195
6-7	PMC-CSL6-7	1505	222	354	4	9069196

BMA air outlet grid

Double louvre grid to be fitted to the duct, to the FMD straight outlet flange or to the FM 90 90° outlet flange. Made of anodized aluminium.

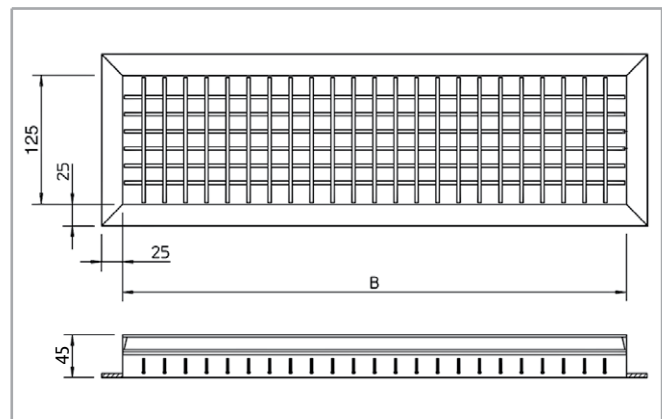

Model	Type	B mm	Code
1	BMA-C3-4	575	9060751
2	BMA-C5-6	775	9060752
3-4	BMA-C7-9	975	9060753
5	BMA-CSL5	1175	9069415
6-7	BMA-C8S	1425	9038040

BXS silencers plenum

Made of galvanised steel metal sheet, lined internally with a reinforced glass wool mat on both sides with a black glass coating; the 50 mm and 30 kg/m³ density lining ensures high noise reduction with very low pressure drops.

Frequency	Hz	125	250	500	1000	2000	4000	8000
Attenuation sound	dB	2,5	5,0	11,5	14,0	13,5	12,0	11,0

NOTE: the silencer plenum reduces the sound levels only on the supply side; the sound levels on the return side are not affected by the silencer.

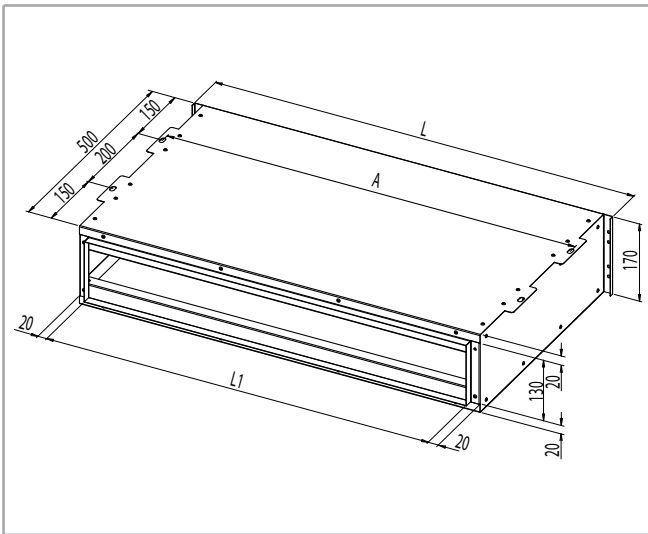

Model	Type	A mm	L mm	L1 mm	Code
1	BXS-A	653	675	597	9069081
2	BXS-B	868	890	812	9069082
3-4	BXS-C	1083	1105	1027	9069083

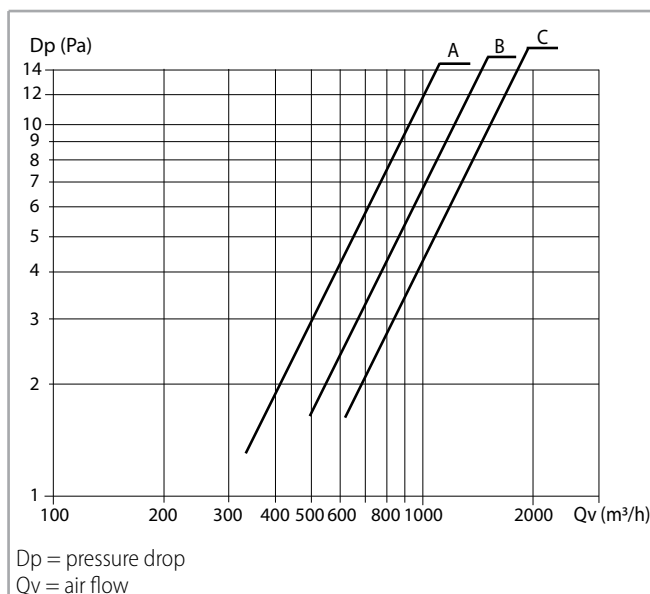



THE INTERNATIONAL CERTIFICATION NETWORK

CERTIFICATE

CISQ/ICIM SPA has issued an IQNet recognized certificate that the organization:

SABIANA S.p.A.

Head Office and Operative Unit
Via Piave, 53 - I-20011 Corbetta (MI)
Operative Unit

Via Virgilio, 2 - I-20013 Magenta (MI)

has implemented and maintains a

Quality Management System

for the following scope:

**Design, production and service of heating and air conditioning equipment
(unit heaters, radiant panels, fan coil units and air handling units) and chimneys.**

which fulfils the requirements of the following standard:

ISO 9001:2015

Issued on: **2018-04-10**

First issued on: **1996-06-10**

Expires on: **2021-04-09**

This attestation is directly linked to the IQNet Partner's original certificate and shall not be used as a stand-alone document.

Registration Number: **IT-4000**

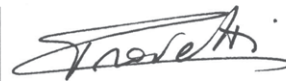

Alex Stoichitoiu
President of IQNET

Ing. Claudio Provetti
President of CISQ

IQNet Partners*:

AENOR Spain AFNOR Certification France APCER Portugal CCC Cyprus CISQ Italy
CQC China CQM China CQS Czech Republic Cro Cert Croatia DQS Holding GmbH Germany FCAV Brazil
FONDONORMA Venezuela ICONTEC Colombia Inspecta Sertifiointi Oy Finland INTECO Costa Rica
IRAM Argentina JQA Japan KFQ Korea MIRTEC Greece MSZT Hungary Nemko AS Norway NSAI Ireland
NYCE-SIGE Mexico PCBC Poland Quality Austria Austria RR Russia SII Israel SIQ Slovenia
SIRIM QAS International Malaysia SQS Switzerland SRAC Romania TEST St Petersburg Russia TSE Turkey YUQS Serbia
IQNet is represented in the USA by: AFNOR Certification, CISQ, DQS Holding GmbH and NSAI Inc.

* The list of IQNet partners is valid at the time of issue of this certificate. Updated information is available under www.iqnet-certification.com



CERTIFICATO n. 0545/7
 CERTIFICATE No. _____

SI CERTIFICA CHE IL SISTEMA DI GESTIONE PER LA QUALITÀ DI
 WE HEREBY CERTIFY THAT THE QUALITY MANAGEMENT SYSTEM OPERATED BY

SABIANA S.p.A.

Sede e Unità Operativa: Via Piave, 53 - 20011 Corbetta (MI)
 Direzione e uffici amministrativi, progettazione, produzione di apparecchiature per il riscaldamento e il condizionamento dell'aria (aerotermi, termostrisce radianti, unità trattamento aria) e canne fumarie.

Unità Operativa: Via Virgilio, 2 - 20013 Magenta (MI)
 Produzione di ventilconvettori, magazzino e logistica

Italia

È CONFORME ALLA NORMA / IS IN COMPLIANCE WITH THE STANDARD

UNI EN ISO 9001:2015

Sistema di Gestione per la Qualità / Quality Management System

PER LE SEGUENTI ATTIVITÀ / FOR THE FOLLOWING ACTIVITIES

EA: 18

Progettazione, produzione e assistenza di apparecchiature per il riscaldamento e il condizionamento dell'aria (aerotermi, termostrisce radianti, ventilconvettori e unità trattamento aria) e canne fumarie.

Design, production and service of heating and air conditioning equipment (unit heaters, radiant panels, fan coil units and air handling units) and chimneys.

Riferirsi alla documentazione del Sistema di Gestione per la Qualità aziendale per l'applicabilità dei requisiti della norma di riferimento.
 Refer to the documentation of the Quality Management System for details of application to reference standard requirements.

Il presente certificato è soggetto al rispetto del documento ICIM "Regolamento per la certificazione dei sistemi di gestione" e al relativo Schema specifico.
 The use and the validity of this certificate shall satisfy the requirements of the ICIM document "Rules for the certification of company management systems" and specific Scheme.

Per informazioni puntuali e aggiornate circa eventuali variazioni intervenute nello stato della certificazione di cui al presente certificato, si prega di contattare il n° telefonico +39 02 725341 o indirizzo e-mail info@icim.it.
 For timely and updated information about any changes in the certification status referred to in this certificate, please contact the number +39 02 725341 or email address info@icim.it.

Data emissione
 First issue
 10/06/1996

Emissione corrente
 Current issue
 10/04/2018

Data di scadenza
 Expiring date
 09/04/2021

ICIM S.p.A.

Piazza Don Enrico Mapelli, 75 - 20099 Sesto San Giovanni (MI)
 www.icim.it



SGQ N° 004 A PRD N° 004 B
 SGA N° 005 D PRS N° 082 C
 SGE N° 005 H ISP N° 046 E
 SCR N° 006 F ETS N° 003 O
 SSI N° 008 G EMAS N° 001 P

Membro degli Accordi di Mutuo Riconoscimento EA, IAF e ILAC
 Signatory of EA, IAF and ILAC Mutual Recognition Agreements



www.cisq.com

CISQ è la Federazione Italiana di Organismi di Certificazione dei sistemi di gestione aziendale.
 CISQ is the Italian Federation of management system Certification Bodies.



A company of Arbonia Group
ARBONIA ▲



SABIANA SpA

società a socio unico
via Piave 53 - 20011 Corbetta (MI) Italy
+39 02 97203 r.a. - +39 02 9777282
info@sabiana.it
www.sabiana.it